



Ship Security – Hull Vulnerability Study

(First edition 2019)



Issued by the

Oil Companies International Marine Forum

29 Queen Anne's Gate

London SW1H 9BU

United Kingdom

Telephone: +44 (0)20 7654 1200

Email: enquiries@ocimf.org

www.ocimf.org

First edition 2019

© Oil Companies International Marine Forum

The Oil Companies International Marine Forum (OCIMF)

is a voluntary association of oil companies having an interest in the shipment and terminalling of crude oil and oil products. OCIMF is organised to represent its membership before, and consult with, the International Maritime Organization (IMO) and other government bodies on matters relating to the shipment and terminalling of crude oil and oil products, including marine pollution and safety.

Terms of Use

While the advice given in this information paper ("Paper") has been developed using the best information currently available, it is intended purely as guidance to be used at the user's own risk. No responsibility is accepted by the Oil Companies International Marine Forum ("OCIMF"), the membership of OCIMF or by any person, firm, corporation or organisation (who or which has been in any way concerned with the furnishing of information or data, the compilation or any translation, publishing or supply of the Paper) for the accuracy of any information or advice given in the Paper or any omission from the Paper or for any consequence whatsoever resulting directly or indirectly from compliance with, or adoption of or reliance on guidance contained in the Paper even if caused by a failure to exercise reasonable care.

Contents

Glossary	iii
Abbreviations	iv
1 Introduction	1
1.1 Purpose	1
1.2 Scope of study	1
1.3 Summary of results	1
2 Study parameters	3
2.1 Vessel modelled	3
2.2 Threats used to determine vulnerability	4
2.3 Fire	4
3 Results	5
3.1 General comments	5
3.2 Anti-Ship Missile	5
3.3 Water-Borne Improvised Explosive Device	7
3.4 Anti-Tank Guided Weapon	8
4 Risk mitigation measures	9
4.1 Adopting a brace position	9
4.2 Muster points	9
4.3 Personal protection	10
4.4 Armoured bridge	10
4.5 Shock protection of critical equipment	10
4.6 Water-mist system for firefighting and blast suppression	10
4.7 Blast doors	10
4.8 Propulsion system redundancy	10
4.9 Improved survival of electrical power systems	11
4.10 Side Protection Systems	11
5 Conclusions	12

Glossary

Aframax Average Freight Rate Assessment (AFRA) tanker that is typically between 80,000 and 115,000 tonnes deadweight.

Anti-Ship Missiles (ASM) Guided missiles that are designed for use against vessels.

Anti-Tank Guided Weapon (ATGW) A guided missile primarily designed to hit and destroy heavily armoured military vehicles.

Crew Anyone legally onboard a vessel.

Critical equipment and systems Any vessel-based equipment, operating system or alarm that, were it to fail, could lead to an accident or would result in the crew or the vessel being placed at risk. Critical equipment or systems should include as a minimum: fire detection and fire-fighting systems, vessel evacuation systems, crankcase oil mist detectors, steering gear, emergency generator, main engine shutdown alarms, propulsion and positioning systems and ventilation and air conditioning systems. If redundancy is provided for operational reasons, equipment should not be considered non-critical.

Free-fall lifeboat A survival craft that drops to the waterline solely under the influence of gravity and is not attached to the davit once it has been released.

Improvised Explosive Device (IED) A bomb constructed and deployed in ways other than in conventional military action.

Safe muster point A designated area chosen to provide maximum physical protection to the crew.

Thermobaric weapon Type of explosive that uses oxygen to generate a high-temperature explosion. It usually produces a much longer-lasting blast wave than a conventional condensed explosive.

Waterborne Improvised Explosive Device (WBIED) An IED delivered by a waterborne craft.

Abbreviations

AFRA	Average Freight Rate Assessment
ASM	Anti-Ship Missile
ATGW	Anti-Tank Guided Weapon
IED	Improvised Explosive Device
kPa	kilopascal
SPS	Side Protection System
SS	Steam Ship
TNT	Trinitrotoluene
WBIED	Waterborne Improvised Explosive Device

1 Introduction

1.1 Purpose

Several OCIMF members recently raised concerns about increasing attacks against vessels from missiles, crafts carrying Improvised Explosive Devices (IEDs) and hand-held Anti-Tank Guided Weapons (ATGWs). Due to regional conflict, new threats emerged in October 2016. Analysis of recent incidents has shown that the stern of the hull is a likely target area, especially on tankers.

This information paper has been developed to highlight the results of the study in relation to the protection of crew and vessels. The results can be applied to both existing and new build vessels.

1.2 Scope of study

OCIMF collaborated with QinetiQ, a multinational defence company, to conduct a computer-based simulation study. The simulations were created by QinetiQ's Survive tool to investigate the vulnerability of a laden Aframax-size tanker's hull with the crew at a heightened state of readiness. This type of vessel was chosen for the study because its hull construction is a common tanker form.

The aim of the study was to determine, following attacks by Anti-Ship Missiles (ASMs), Water-Borne IEDs (WBIEDs) and ATGWs:

- The likelihood of injury to seafarers.
- The effect on crew evacuation routes.
- The scale of damage.

The study used computer-based simulation to assess the vulnerability of an Aframax-size tanker to a range of credible threats: a representative ASM, a WBIED and an anti-tank missile. The analysis considered personnel survival, the integrity of the hull and internal bulkheads and the vulnerability of critical systems. The results were evaluated quantitatively using focussed modelling and qualitatively by naval architects and vulnerability design experts.

1.3 Summary of results

The study concluded the following:

- The WBIED modelled is capable of:
 - Inflicting blast-related fatalities and injuries.
 - Causing extensive damage to the hull and superstructure plates due to blast and shock, resulting in flooding of the machinery spaces.
 - Blast and shock damage to the propulsion and steering system and to the electrical power system.
 - Damaging escape routes and lifesaving appliances due to blast.
- The effects of the ASM and ATGW modelled are localised in the impact area:
 - No flooding is predicted.
 - Damage to the vessel's critical systems is unlikely.
 - Escape routes and lifeboats/rafts may be susceptible to damage.
 - Crew injuries are possible, and if a weapon hits an occupied space, such as the bridge, multiple serious injuries and fatalities can occur.

When operating in areas where threats of ASMs, ATGWs and WBIEDs have been identified, this study highlights the following for consideration:

- Mustering the crew at a point other than the citadel (if in the engine room) and providing ballistic protection at this alternative point.
- Securing or removing potentially hazardous material and equipment from crew muster points.
- Providing the crew with additional or specialist firefighting equipment and training.
- Ensuring the crew are familiar with all escape routes.
- Providing body armour and ear defenders.
- Adding structural armouring to high-value exposed locations, such as the bridge.
- Providing additional protection to critical equipment and escape route doors against blast and shock damage against weapon effects.
- Enhancing firefighting and blast suppression systems.

For new build vessels, this study highlights:

- Duplicating critical systems as a consideration for future design, including the vessel's main engine and electrical power generators. This is similar to the duplication of navigational tools and systems that is often already in place on vessels.
- Installing Side Protection Systems (SPSs) to limit hull damage from IED explosions. Future design is influenced by many factors, and this possibility is included as an innovative research and development idea for vessel designers to explore for feasibility and cost-risk assessment.

2 Study parameters

2.1 Vessel modelled

The vessel used for analysis was a modern Aframax-size tanker with the following dimensions:

- Length: 250.5m.
- Beam (max): 44m.
- Draught: 12m.

The hull was constructed in steel that was between 14 and 34mm thick.

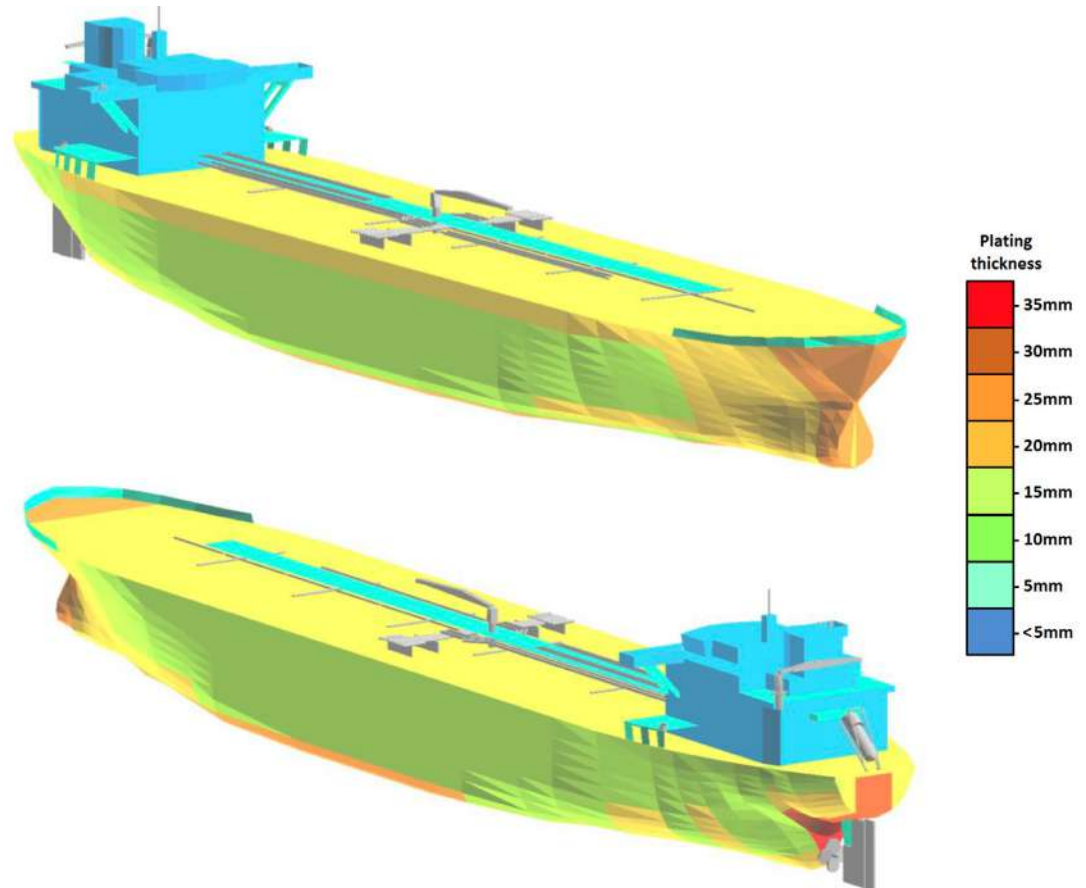

Figure 2.1: Model of an Aframax tanker from the simulation study

The critical equipment and systems modelled were:

- Propulsion and steering:
 - Main engine.
 - Propeller and propeller shaft.
 - Steering.
 - Electrical power generation and distribution.
 - Engine control room and crew.
 - Bridge crew.
- Vessel communications.
- Escape systems.

The escape systems modelled were a free-fall lifeboat and four liferafts, as well as stairways and escape routes between decks. The simulation showed that damage to any single flight of stairs (for example, between adjacent decks or landings) would make the entire stairway unusable.

The model had a crew of 32, including 2 in the engine control room, 7 on the bridge deck and extra lookouts and security team. The remaining crewmembers were positioned in the central stairwell, which is a common secondary safe muster point.

2.2 Threats used to determine vulnerability

2.2.1 Anti-Ship Missile

The missile used in the simulation was a generic representation of a subsonic turbo-jet powered ASM with a warhead containing 55kg of explosive. This type of weapon was fired at tankers in the Red Sea (as a result of the conflict in Yemen spilling into the maritime domain in 2018) and caused considerable damage. For this study, the missile followed a horizontal, sea-skimming trajectory, impacting the vessel somewhere above the waterline.

2.2.2 Water-Borne Improvised Explosive Device

The WBIED used in the simulation was a small craft carrying explosives. The threat modelled in the study was a 300kg trinitrotoluene (TNT) charge, detonating on the waterline. The nature and weight of explosives will affect the degree of shock, blast and structural damage they generate.

2.2.3 Anti-Tank Guided Weapon

The simulation used a hand-held ATGW with a thermobaric blast warhead equivalent to 10kg of TNT and another variant with two shaped charges. For the simulation, the missile followed a horizontal, sea-skimming trajectory.

2.3 Fire

Fires were not modelled as part of this study, but any of the threats modelled can result in a fire. The effects of shock can also damage or displace equipment and pipes, resulting in fire.

3 Results

3.1 General comments

Modelling procedures were set up to explore several locations where a simulated weapon might hit a vessel and the effects of the hit. This provided information on:

- The likely number of casualties.
- The probability that safety critical and communications equipment will survive a hit.
- Likely damage to the hull and primary structure from blast or kinetic energy and the effect of that damage on the vessel's residual strength.
- How many compartments would be flooded if the hull was breached below the waterline, and whether this would compromise the stability of the vessel.
- Secondary damage mechanisms, such as how blast and smoke spread through the vessel and their effects on equipment, structure and crew.

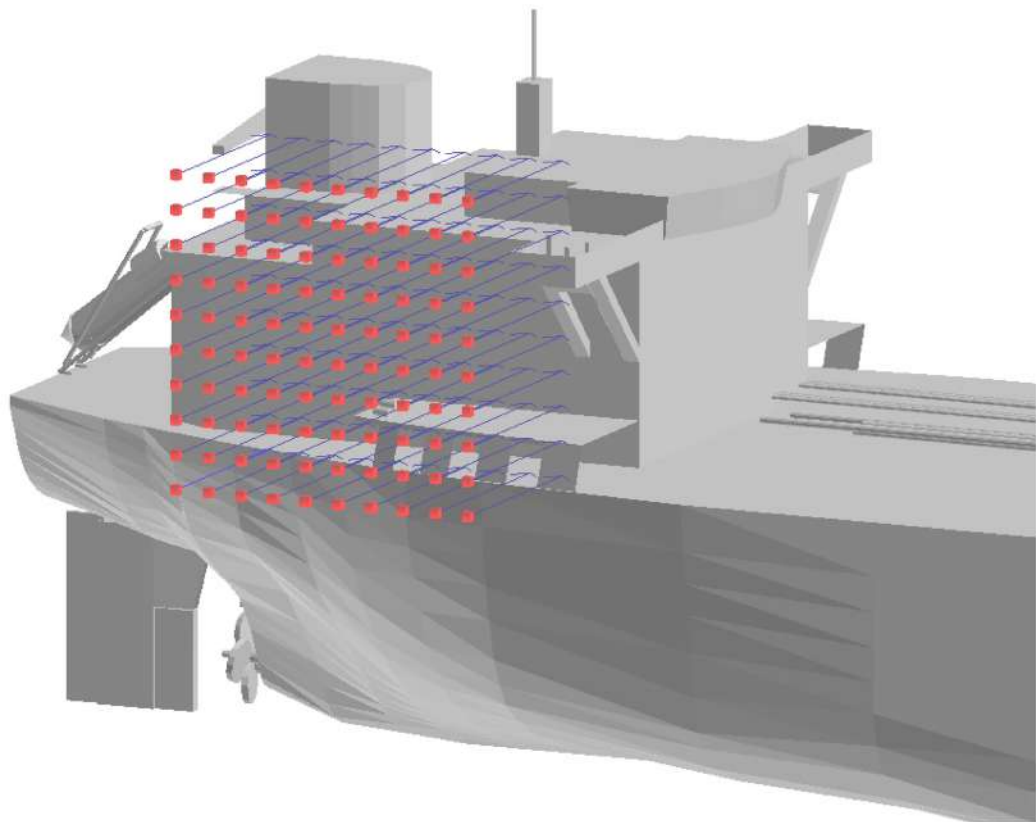

Figure 3.1: Example from the simulation study showing contact points modelled, showing the contact points where the simulated weapons hit the vessel

3.2 Anti-Ship Missile

3.2.1 Crew casualties

Some points of impact modelled for ASMs resulted in fatalities, such as a direct hit to the bridge. For other points of impact, and given the crew distribution profile adopted, the average results showed few casualties. Crewmembers located in the central stairwell (the secondary muster point for the study) were largely unaffected by the weapon. Blast pressures in the stairwell were approximately 30 to 40kPa, which is enough to cause injuries.

Effective crew muster points should be chosen based on a risk assessment of both weapon behaviour and the actual level of protection that structures and equipment provide.

3.2.2 Structural effects

The simulation showed that ASMs can penetrate the hull or superstructure. Other than the immediate damage from impact, a few instances of hull plate failure occurred. The hull and main deck plates survived the weapon's blast.

This resilience is likely because, when impacting the hull, an ASM often detonates in a large internal compartment where blast overpressures dissipate before the hull's blast failure levels are reached. Very low peak pressures were found in the engine room compartment following these simulated attacks. When detonating in the hull's smaller compartments, the compartment bulkheads in this study tended to fail before the hull plates, again dissipating blast internally.

3.2.3 Systems effects

As well as the blast damage, this study suggests that warhead fragments are likely to perforate multiple internal bulkheads and damage critical equipment. An example of the fragment spread from an attack is shown in figure 3.2, where each coloured line represents the potential path of a fragment. If there is enough momentum, this can cause crew injury and damage to equipment.

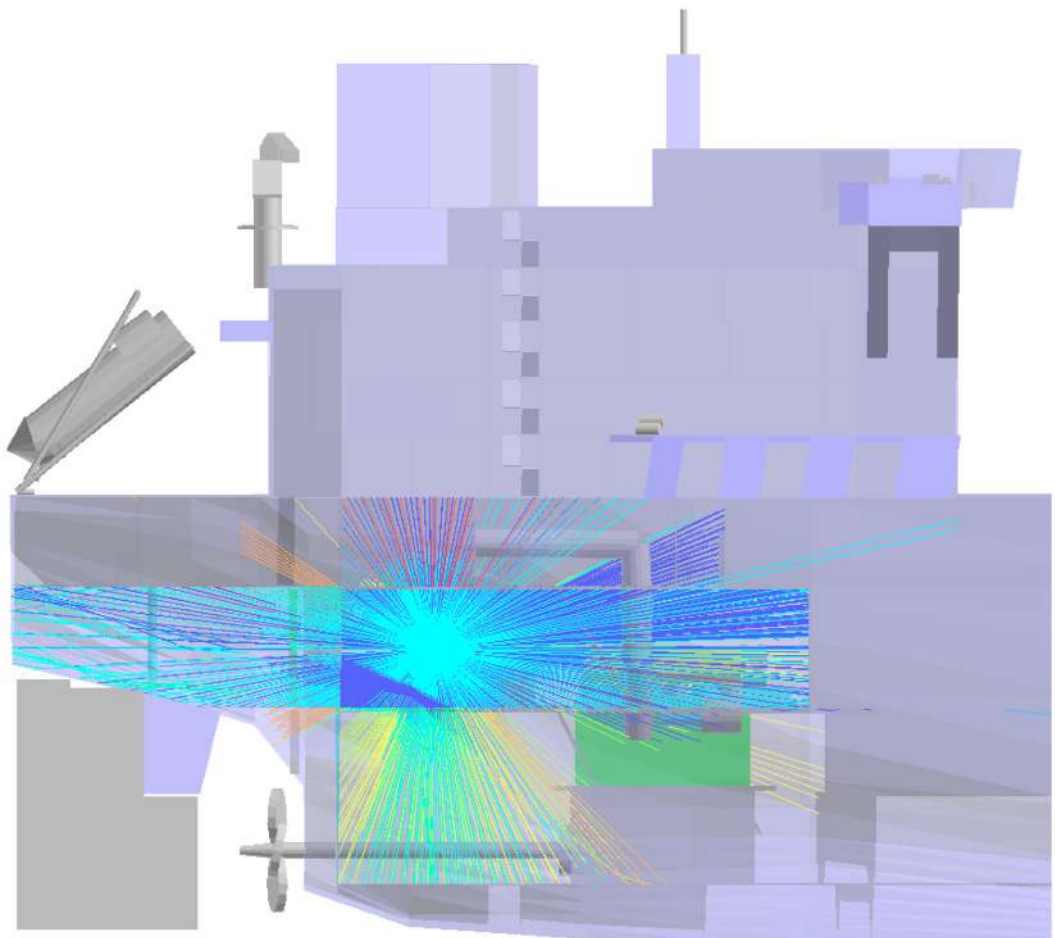

Figure 3.2: Example of fragment spread from the simulation study

3.2.4 Effects on escape routes and safety equipment

The study results suggest that individual escape routes and lifeboats/liferafts are vulnerable to the ASM modelled. Some simulated impact conditions destroyed the free-fall lifeboat, the liferafts and the side wing stairwell. However, overall, in this simulation, no single attack was able to destroy or disable enough of the survival craft to prevent evacuation. The simulated damage was sufficiently localised, so alternative escape routes will likely still be available following an ASM attack.

Effective training and awareness of alternative escape routes are vital to crew safety.

3.3 Water-Borne Improvised Explosive Device

3.3.1 Crew casualties

The simulations predicted few crew casualties from a WBIED attack. However, crewmembers in the machinery control room or even those in the stairwell can experience blast pressures severe enough to cause eardrum rupture. No serious injuries or deaths were predicted for any of the cases assessed.

Experience shows that crew positioned near doors can also be injured if doors are blown open, but this was not assessed in this study. No crew were modelled below the waterline, but any who are should be considered at risk from flooding. Similarly, no crew were modelled at the waterline, close to the hull on the attack side. However, blast overpressures of up to 1000kPa were recorded in the smaller compartments adjacent to the detonation point and any personnel subjected to these levels would be susceptible to severe blast injuries, potentially including death.

Minimise the number of people in the engine room when the vessel is in a high-risk area.

3.3.2 Structural effects

In this simulation, the detonation of 300kg of TNT next to the hull resulted in a hull breach around 9m in diameter.

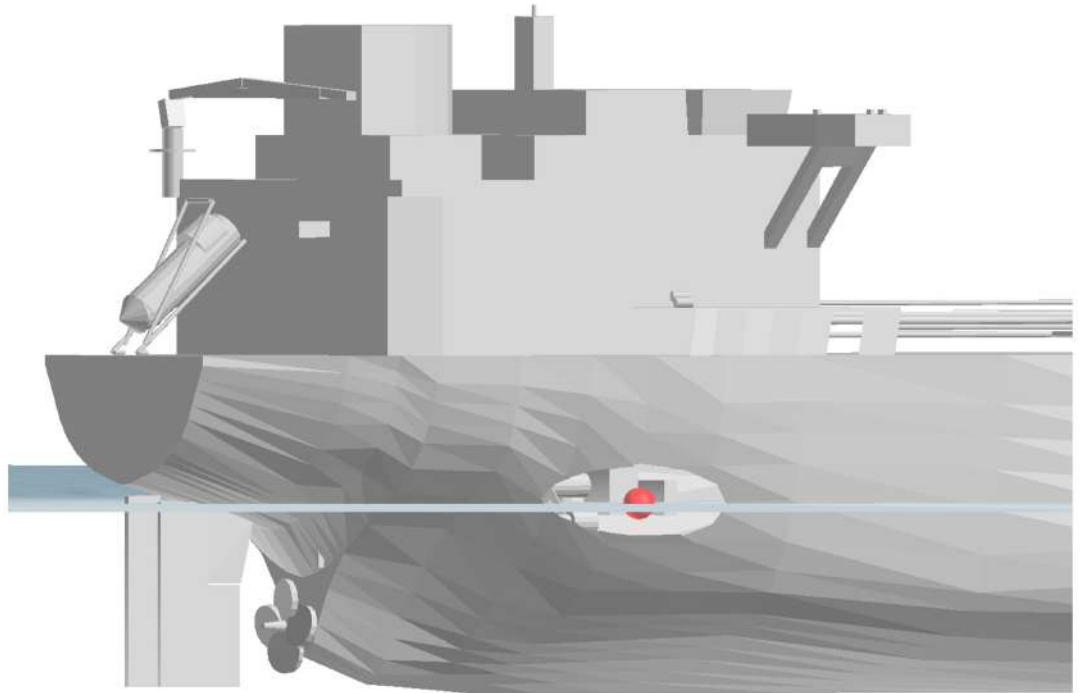

Figure 3.3: Example of a WBIED detonation on the waterline from the simulation study

This loss of plating occurred both above and below the waterline and flooded the machinery spaces. Detonation anywhere around the stern can flood the entire machinery spaces. Attacks in the forward section of the machinery spaces can also breach the bunker tanks and possibly the aftmost cargo compartment.

3.3.3 Systems effects

For a weapon of this type, damage to equipment will arise from several causes, the most significant of which will be flooding and blast. Most equipment affected by flooding is likely to be disabled, including engines and pumps. Some damage from underwater explosive shock is also likely. The transmission of shock into the hull and through the internal structure can cause significant damage to hard-mounted equipment. Any unsecured equipment can cause damage to equipment or people.

The simulation detected blast in the superstructure compartments, with up to 150kPa observed in the engine room, stairwells, air intake and exhaust trunk space. This level of blast is enough to cause injury and to cause failure of most types of doors, including watertight doors, but any structural plates are unlikely to fail.

3.3.4 Effects on escape routes and safety equipment

The simulation showed blast overpressure in the central stairwell, as the doors were blown in. However, for this model, there was no substantial damage to the stairways themselves.

The free-fall lifeboat was vulnerable to shock in the aftmost attacks simulated, but the other survival craft remained usable for evacuation.

3.4 Anti-Tank Guided Weapon

3.4.1 Crew casualties

On average, the simulated ATGW caused low levels of casualties. In some cases, such as if the warhead detonates on the bridge wing, fatalities are likely.

3.4.2 Structural effects

The thermobaric properties of the warhead are predicted to be powerful enough to cause limited blast damage to the superstructure but not the hull. In all but a few cases modelled, only the external shell was damaged, and no substantial internal blast damage was observed. The warhead of the ATGW is not predicted to cause any significant structural damage anywhere on the vessel.

3.4.3 Systems effects

It is unlikely that any critical systems will be lost due to attack from the ATGW modelled. The warheads tend to expend most of their blast outside, since they have focussed shaped charges. Any damage to internal equipment will likely be highly localised.

3.4.4 Effects on escape routes and safety equipment

Escape routes remained available in all the simulated cases modelled. However, specific attacks can damage or destroy individual survival craft.

Because ASM and WBIED attacks are likely to flood the engine room, the study investigated the potential for a boiler explosion in case of rapid flooding. In the last 50 years, many vessels have sunk due to progressive flooding but, except for the SS Ben Lomond in 1942, there have been no confirmed instances of boiler explosions caused by an engine room flood. While it is possible that the sudden drop in the boiler pressure vessel's external temperature due to flood water could cause thermal shock and boiler explosion, this is very unlikely. However, the risk can be mitigated by positioning the boilers well above the load waterline in new build vessels.

4 Risk mitigation measures

This study showed that the threats modelled can cause a number of hazards. It also highlighted some mitigation measures.

4.1 Adopting a brace position

Blast can cause injury in several ways:

- The impact of blast overpressure on organs, e.g. lungs and eardrums.
- The impact on the whole body being blown over.
- Trauma from debris propelled by blast.

Brief the crew on adopting a brace position to help mitigate blast effects. This involves holding onto something solid or pressing against a wall, with feet planted firmly on the deck, and with arms and legs bent.

Adopting a brace position may reduce the second blast effect and lying down may help with the second and third. There is no scientific evidence to support this, but many navies advise adopting a brace position to protect personnel against shock.



Figure 4.1: *Brace position*

4.2 Muster points

Structures, equipment or other items at muster points can be used as makeshift ballistic protection.

All loose items in the muster point should be secured so they do not become hazards if propelled by shock or blast. Crewmembers should stay clear of doors and windows because they can come loose and hit them.

The compartment chosen as the muster point should have at least one alternative entry/exit point and be equipped with tools to free jammed doors.

The study showed that while certain attack profiles can affect escape routes and survival craft, alternatives usually remain available.

This study suggests that mustering non-essential crew in the central stairwell is an effective strategy for the vessel modelled. Crewmembers on the bridge, the bridge wings and the engine control room were all more vulnerable to the threats modelled.

Blast overpressure in the central stairwell can be as high as 100kPa, particularly from the WBIED threat modelled. Pressures of this magnitude can cause injury such as eardrum rupture. Ear defenders are likely to reduce such injuries.

The central stairwell has the advantage of providing access to multiple escape routes and access to emergency response equipment. If another location is used for mustering, then access to alternative escape routes should be identified beforehand.

4.3 Personal protection

Most casualties caused by anti-ship and anti-tank missile threats occurred in this study because of detonations and fragmentation.

The study showed that giving extra protection against fragmentation, such as body armour, to crewmembers on the bridge only had a small effect on casualty numbers. Therefore, it is likely that this type of protection is not effective.

4.4 Armoured bridge

Additional armour can be added to the bridge structure to protect against fragmentation and to increase blast resistance. Refer to the 2014 OCIMF information paper *Ship Security – Bridge Vulnerability Study* for more information.

Armouring the bridge can help to reduce casualties and damage to internal equipment if a threat detonates outside of the bridge. However, a direct hit from a lethal threat such as an ASM will likely penetrate the armour and cause extensive damage.

4.5 Shock protection of critical equipment

If a single piece of equipment is critical to vessel operation, it can be shock protected to improve its chances of survival, as well as those of any system it supports. Equipment considered critical in this study includes the engine control consoles and the switchboard.

4.6 Water-mist system for firefighting and blast suppression

A water-mist fire extinguishing system could improve firefighting capability. Water-mist is also known to reduce blast pressures generated by an explosion and can be used in anticipation of an attack if a threat is sighted or if advance warning is received.

4.7 Blast doors

Industry-standard doors and hatches are unlikely to prevent the spread of blast damage. Blast-proofing key doors and hatches is likely to help control the spread of damage, protect evacuation routes and reduce the risk of fires.

4.8 Propulsion system redundancy

The propulsion and steering system on the vessel modelled were found to be extremely vulnerable to WBIED threats. These systems are vulnerable because the WBIED can cause flooding in the engine room and cause the vessel's only source of motive power to fail.

In theory, the simplest solution is introducing redundancy and separation into the design of new build vessels. This would involve two independently-operated engines in separate watertight compartments, ideally with as much longitudinal separation between them as possible.

To test this theory, the simulation model was modified to include a second engine separated by a single blast-resistant and watertight bulkhead. The propulsion system was also modified so that the loss of one engine would not cause system failure. A WBIED vulnerability analysis of the modified vessel showed that a second, separated engine system can greatly reduce vulnerability.

There are also several vulnerable system-critical items of equipment not located in the engine room. The rudder, the propeller and the stern gland are all susceptible to shock from an underwater explosion and they remain vulnerable even if duplicated. Redundancy and separation of these components has some effect, and twin propellers or twin rudder designs are sometimes used. Furthermore, shock is in some ways more difficult to manage than flooding and equipment can be affected even from very far away. To increase the survivability of critical equipment, shock hardening is more likely to be valuable, especially if equipment is also duplicated.

Due to cost, new tankers are unlikely to include duplicated propulsion systems. An alternative solution is to use an azimuthing bow thruster for emergency propulsion, as this provides some low-powered manoeuvrability.

4.9 Improved survival of electrical power systems

In the vessel modelled, the three main diesel generators were in the same compartment and the backup generator was several decks above in the superstructure. In the study, shock accelerations travelled vertically through the main bulkheads and caused damage to both the main generators and the backup generator when an underwater explosion occurs near their location.

The vessel model was adapted to find out if the electrical distribution system's survival rate could be improved by separating the backup generator both longitudinally and vertically from the main generators. In the model, the backup generator was moved to the front of the superstructure and up two decks. This created many subdivisions between the two locations, which reduced the number of fragments from a fragmenting warhead attack likely to hit both sets of redundant equipment.

4.10 Side Protection Systems

Side protection has been developed by navies over many years to defeat waterline detonations. Based on the results of this study, it can provide protection primarily against WBIED threats, although it will also protect against missile threats. The principles of the Side Protection System (SPS) concept are shown in figure 4.2.

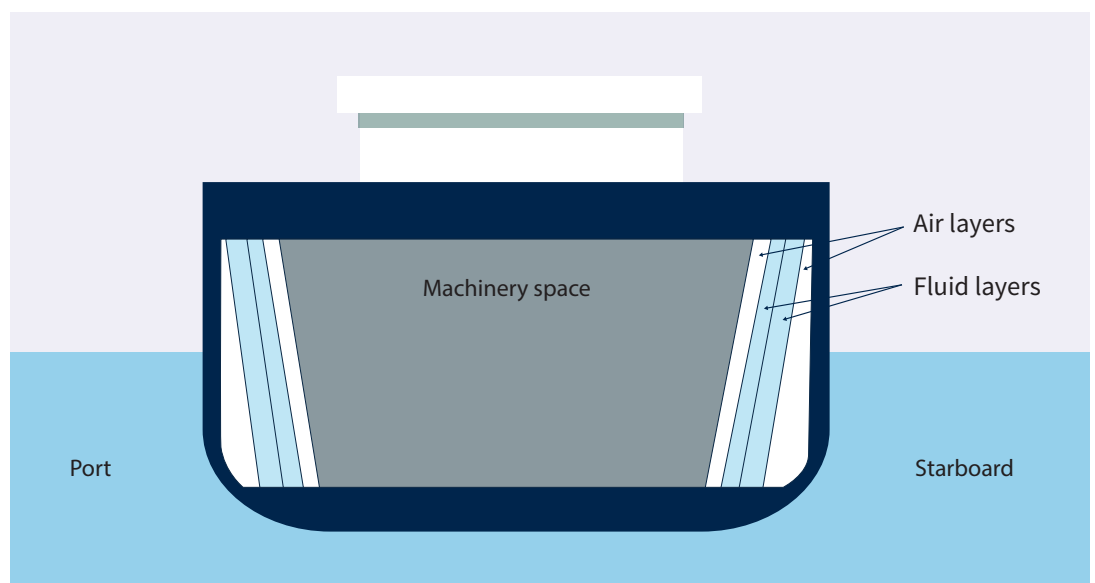

Figure 4.2: Side Protection System concept

5 Conclusions

This study assessed the vulnerability of a generic tanker hull (Aframax) to threats such as those experienced in the Red Sea in 2018. It modelled credible anti-ship weapons, including an ASM with a fragmenting warhead containing 55kg of explosive, a 300kg TNT WBIED and a common ATGW. The study considered a range of possible damage outcomes, including localised structural damage, flooding, failure of critical equipment and systems (including escape systems) and human casualties. The study did not assess large-scale structural failure, fire or loss of stability due to flooding.

The study concluded:

- The ASM and ATGW modelled can cause damage that is considerably more localised. For the most likely attack profiles, no flooding is predicted. Significant damage to the vessel's critical systems is unlikely. Escape routes and survival craft are susceptible to damage. Crew injuries are likely and, if the weapon hits an occupied space, such as the bridge, multiple serious injuries and fatalities can be expected.
- The 300kg WBIED modelled can cause widespread damage to hull plates and superstructure due to blast and shock. This is predicted to result in extensive flooding of the internal machinery spaces, particularly the engine room. Blast and shock damage to the propulsion and steering system and to the electrical power system are also expected. The crew is at risk of minor blast injuries, but no incapacitating injuries or fatalities are expected for the crew distribution profile modelled. Individual escape routes and survival craft are susceptible to blast.



A voice for safety

**Oil Companies
International Marine Forum**
29 Queen Anne's Gate
London SW1H 9BU
United Kingdom

T +44 (0)20 7654 1200
E enquiries@ocimf.org
ocimf.org