



Ref. T4/4.01

MSC.1/Circ.1321  
11 June 2009

**GUIDELINES FOR MEASURES TO PREVENT FIRES IN ENGINE-ROOMS  
AND CARGO PUMP-ROOMS**

1 The Maritime Safety Committee, at its seventy-ninth session (1 to 10 December 2004), recognized the need for the development of practical guidelines for measures to prevent fires in engine-rooms and cargo pump-rooms, taking into account relevant IMO instruments and present engineering and shipbuilding technology.

2 The Committee, at its eighty-sixth session (27 May to 5 June 2009), having considered a proposal by the Sub-Committee on Fire Protection, at its fifty-third session, approved the Guidelines for measures to prevent fires in engine-rooms and cargo pump-rooms, set out in the annex.

3 Member Governments are invited to bring the annexed Guidelines to the attention of ship designers, owners, operators, shipbuilders and other parties concerned.

\*\*\*



**ANNEX****GUIDELINES FOR MEASURES TO PREVENT FIRE IN ENGINE-ROOMS AND  
CARGO PUMP-ROOMS****CONTENTS****PART 1 GENERAL**

- 1 Purpose
- 2 Application
- 3 Definitions

**PART 2 INSTALLATION PRACTICE****Chapter 1 General**

- 1 General requirements

**Chapter 2 Piping system**

- 1 Design and construction
- 2 Flexible pipes, hoses and hose assemblies
- 3 Bellows expansion joints
- 4 Filters and strainers
- 5 Insulation materials
- 6 Pressure, temperature, oil level gauges and sight glasses
- 7 Pipe fittings

**PART 3 ENGINE-ROOMS****Chapter 1 Control of flammable oils**

- 1 Arrangement and installation of pressurized oil fuel systems
- 2 Spray shields for joints of pressurized flammable oil piping systems
- 3 Jacketed high pressure fuel lines of internal combustion engines

**Chapter 2 Control of ignition source**

- 1 Insulation of hot surfaces and high temperature surfaces
- 2 Protection of electrical equipment
- 3 Identification and protection of potential ignition sources

**Chapter 3 Control of ventilation**

- 1 Design of ventilation systems

**Chapter 4 Useful arrangement, installation and apparatus for fire safety**

- 1 Measures for the prevention of spillage of flammable oils
- 2 Fuel oil isolation valves for multi-engines

**Chapter 5      Equipment installation**

- 1      Boilers
- 2      Thermal oil installations
- 3      Purifier rooms
- 4      Oil heaters
- 5      Hydraulic power packs

**PART 4      CARGO PUMP-ROOMS**

**Chapter 1      Control of flammable materials**

- 1      General
- 2      Equipment and fittings on cargo piping systems

**Chapter 2      Control of ignition source**

- 1      General
- 2      Lighting system and protection of electrical equipment
- 3      Protection of penetration to other spaces
- 4      Temperature monitoring system for pumps in cargo pump-rooms

**Chapter 3      Control of ventilation**

- 1      Design criteria of ventilation systems
- 2      Gas detection systems

## PART 1

### GENERAL

#### 1 Purpose

1.1 These Guidelines are a consolidation of the measures to prevent fire in engine-rooms, cargo pump-rooms and other fire-prone spaces based on present engineering and shipbuilding technology, including resolutions, circulars and other documents developed by IMO.

1.2 The purpose of these Guidelines is to provide uniform and harmonized guidance in a single document to shipowners, ship designers, shipmasters, inspectors and surveyors. Also this minimizes the deviation of interpretation or application standards among inspectors, surveyors and Member States.

1.3 Attention is drawn to the importance of the design, construction, testing, installation, inspection and maintenance of systems containing flammable oils in order to reduce the risk of fire.

1.4 The Guidelines have been developed without prejudice to the requirements of existing SOLAS regulations, MSC circulars and other IMO safety instruments.

#### 2 Application

2.1 These Guidelines are intended for application of fire safety engineering design to provide technical justification and installation guidance on measures to prevent fire in engine-rooms, cargo pump-rooms and other fire-prone spaces.

2.2 These Guidelines do not cover fire hazards related to the arrangements for gas fuels which must satisfy the relevant Codes and regulations developed by IMO.

#### 3 Definitions

3.1 *Flashpoint* means the temperature in degrees Celsius (closed cup test) at which a product will give off enough flammable vapour to be ignited, as determined by an approved flashpoint apparatus.

3.2 *Auto-ignition point* means the temperature at which a substance will spontaneously combine with oxygen and burn without an external ignition or heat source.

3.3 *High temperature surfaces* means surfaces with temperatures above 220°C.

3.4 *Hot surfaces* means surfaces with a temperature of less than 220°C including steam systems with a pressure of less than 2.3 N/mm<sup>2</sup>, thermal oil systems, exhaust gas piping and oil-fired and exhaust gas boilers.

3.5 *Heated surfaces* means surfaces with a high temperature source on the other side.

3.6 *Potential ignition sources* means sources having enough energy to cause ignition. These include high temperature surfaces, sparks or flames from inefficient flanges or joints, electrical discharges caused from electrostatic atmospheres, or electrical contactor faults. Sources of these are for example exhaust gas piping of internal combustion engines, leakages from boiler furnace joints and electrical equipment within oil treatment rooms.

3.7 *Flammable oils*, for the purpose of these Guidelines, means those oils used in machinery spaces such as those listed in table 1.

3.8 *Flammable oil system* means the system used for the supply of flammable liquid to engines or equipment.

3.9 *Lower flammable limit (LFL)* means the concentration of a hydrocarbon gas in air below which there is insufficient hydrocarbon to support and propagate combustion.

## PART 2

### INSTALLATION PRACTICE

#### CHAPTER 1 – GENERAL

#### 1 General requirements

##### 1.1 *Fire triangle*

The interaction of the three equal sides of the fire triangle: HEAT, FUEL AND OXYGEN, are required for the creation and maintenance of fire. When there is not enough heat generated to sustain the process, when the fuel is exhausted, removed or isolated, or when oxygen supply is limited, then a side of the triangle is broken and the fire is suppressed.

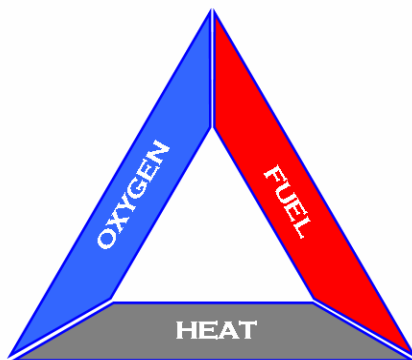

**Figure 2-1 – Fire triangle**

For flammable liquids, the idea of the fire triangle is generally embodied in fire prevention by excluding the flammable mixture of oil (LFL) and (or) hot spots (Auto Ignition Point). Given 21% O<sub>2</sub> concentration in the atmosphere, for a flammable oil, the flammable mixture (LFL) can exist at the temperature of its flashpoint (FP) and above.

##### 1.2 *SOLAS requirements to break the fire triangle chain*

###### 1.2.1 Fuel control

Many kinds of flammable oils are used in ships.

When flammable oils are leaked or splashed in engine-room spaces or where potential ignition sources exist, they may cause a fire depending on the situation. To prevent leaks, splashes or spray from flammable oil service or transfer piping systems, the following measures need to be considered as described in SOLAS:

- .1 spray shields for flanged/screwed joints of pipes containing flammable oils (fuel oil, lubricating oil and hydraulic oil);
- .2 jacketed piping system for high pressure fuel pipes;
- .3 flammable oil piping location;

- .4 tank sounding pipes, air vents and level measuring devices location; and
- .5 flammable gas measurement systems.

### 1.2.2 Heat control

Many hot surfaces and potential ignition sources exist in engine-rooms, cargo pump-rooms and other fire-prone spaces. To assist in preventing a fire originating as a result of flammable oil coming in direct contact with high temperature surfaces, these surfaces should be properly insulated.

Therefore, the SOLAS regulations require:

- .1 insulation of high temperature surfaces;
- .2 temperature sensing devices for cargo pumps, ballast pumps and stripping pumps installed in cargo pump-rooms and driven by shafts passing through the pump-room bulkhead;
- .3 the surface of any insulation used in spaces where penetration of oil is possible (e.g., machinery spaces) to be impervious to oil or oil vapours. This applies equally in cases where the insulation is applied to meet shipyard practice or at the owner's request, for example to reduce heat loss or to protect the crew; and
- .4 spray protection of some electrical equipment.

### 1.2.3 Oxygen control

It is not possible to exclude air from engine-rooms or pump-rooms except when actively suppressing a fire, so control of oxygen supply is not a practical means of preventing fire in these spaces. However, cargo tanks or slop tanks which are part of a cargo area could be inerted using an inert gas system.

To decrease the flammable vapours within cargo pump-rooms SOLAS requires such spaces to be mechanically ventilated. The number of air changes shall be at least 20 per hour, based upon the gross volume of the space. The ventilation shall be of the suction type using fans of the non-sparking type.

## 1.3 *Specification of flammable oils*

Flammable oils have different flashpoints and auto-ignition points. The actual ignition condition may differ from the flashpoint and auto-ignition point. Table 1 shows the typical flashpoint and auto-ignition point of various flammable oils used on board ship.



**Table 1 – Typical flashpoint and auto-ignition point**

		Flashpoint (°C)	Auto-ignition point (°C)
Heavy oil fuel		65~80	min. 400
Intermediate oil fuel 380		60~75	min. 250
Intermediate oil fuel 180		60~75	min. 250
Medium oil fuel		60~75	min. 250
Marine diesel oil		60~75	min. 250
Marine gas oil		60~75	min. 250
Lubricating oil	Cylinder oil	210~240	min. 320
	System oil	250~255	min. 320
Hydraulic oil		180	min. 320
Thermal oil		210	min. 320

### 1.3.1 Flashpoint of oil fuel

- .1 Oil fuels with a flashpoint of less than 60°C (closed cup test) are not permitted, except for the following:
  - .1 ships certified for restricted service within areas having a climate ensuring that ambient temperatures of spaces where such oil fuel is stored will not rise to within 10°C below its flashpoint, but not less than 43°C;
  - .2 installations complying with IACS UR M24 regarding use of crude oil as fuel; and
  - .3 in emergency generators oil fuel with a flashpoint of not less than 43°C may be used.
- .2 Oil fuel in storage tanks should not be heated to temperatures within 10°C below the flashpoint of the oil fuel, except for the following:
  - .1 oil fuel in service tanks, settling tanks and any other tanks in the supply system may be heated above this limit, provided:
    - .1.1 the length of the vent pipes from such tanks is sufficient for cooling the vapours to at least 10°C below the flashpoint of the oil fuel;
    - .1.2 a temperature sensor is fitted in the vent pipe and adjusted to give an alarm if the temperature should exceed a limit set at 10°C below the flashpoint of the oil fuel;
    - .1.3 the vent pipes are fitted with flame screens meeting the requirements of IMO's "Standards for devices for preventing passage of flames into cargo tanks";
    - .1.4 there are no openings from the vapour space of the oil fuel tanks into machinery spaces, (bolted manholes are acceptable);

- .1.5 enclosed spaces should not be located directly over such oil fuel tanks, except for well ventilated cofferdams; and
- .1.6 electrical equipment should not be fitted in the vapour space of the oil fuel tanks, unless it is certified to be intrinsically safe.

## **CHAPTER 2 PIPING SYSTEM**

### **1 Design and construction**

#### **1.1 General**

For the application of these Guidelines, flammable oil systems are classified as follows:

- .1 high pressure oil system:
  - a piping system which services or transfers flammable oils having pressures of 10.0 N/mm<sup>2</sup> or above; and
- .2 low pressure oil system:
  - a piping system which services or transfers flammable oils having pressures between 0.18 N/mm<sup>2</sup> and 10.0 N/mm<sup>2</sup>.

#### **1.2 Pressurized oil fuel system**

If oil fuel lines fail, spray patterns may occur. These spray patterns depend on the pressure of the system and the failure condition. Major factors of flammability are air/fuel mixture ratio, temperature of fuel and droplet size. Droplet diameter is one of the factors and is dependent on fluid pressure and size of failure. As a general rule, the smaller the droplet size the greater the fire risk when the fuel system is under high pressure and a small orifice exists, as this results in the atomization of the fuel oil. Therefore, a small crack in a high-pressure oil fuel pipe may lead to a most dangerous situation.

### **2 Flexible pipes, hoses and hose assemblies**

#### **2.1 Application**

Flexible pipes, hoses and hose assemblies – which are flexible hoses with end fittings attached – should be in as short lengths as practicable, but should not, in general, exceed 1.5 m in length, and only be used where necessary to accommodate relative movement between fixed piping and machinery parts.

#### **2.2 Design and construction**

Hoses should be constructed to a recognized standard and be approved as suitable for the intended service, taking into account fire resistance, pressure, temperature, fluid compatibility and mechanical loading including impulse where applicable. Each type of hose assembly should be provided with a certificate of hydrostatic pressure testing and conformity of production.

## 2.3 Installation

Hoses should be installed in accordance with the manufacturers' instructions, having regard to: minimum bend radius, twist angle and orientation, and support where necessary. In locations where hoses could possibly suffer external damage, adequate protection should be provided. After installation, the system should be operated at maximum pressure and checked for possible malfunctions and leakages.

## 2.4 Installation guidelines

Flexible hoses should:

- .1 avoid sharp bends;
- .2 have end fittings torqued in accordance with manufacturer's specifications;
- .3 consider fluid flow; and
- .4 consider movement of attached bodies.

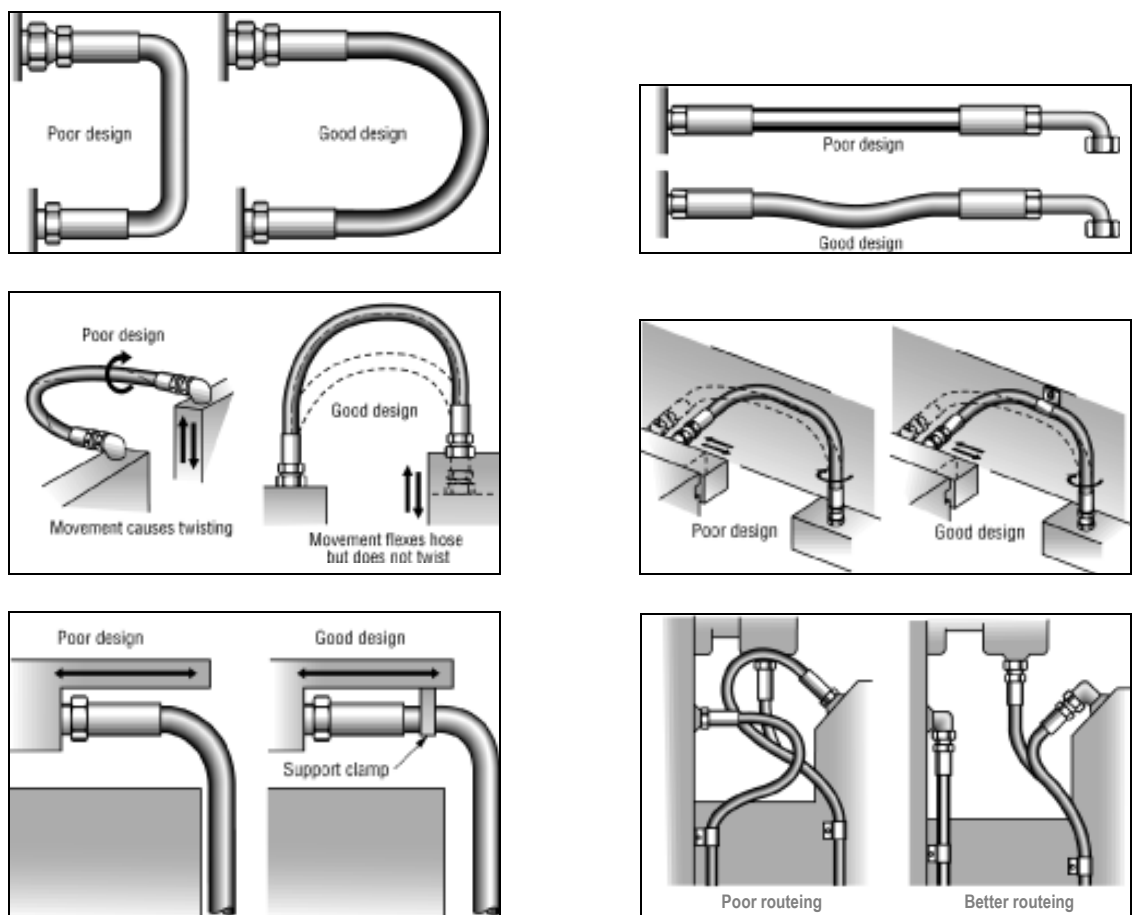

Figure 2-2 – Example of correct installation of flexible hoses

## **2.5 Inspection and maintenance**

2.5.1 Hose assemblies should be inspected frequently and maintained in good order or replaced when there is evidence of distress likely to lead to failure. Any of the following conditions may require replacement of the hose assembly:

- .1 leaks at fitting or in flexible hose;
- .2 damaged, cut or abraded cover;
- .3 kinked, crushed, flattened or twisted flexible hose;
- .4 hard, stiff, heat cracked or charred flexible hose;
- .5 blistered, soft, degraded or loose cover;
- .6 cracked, damaged or badly corroded fittings; and
- .7 fitting slippage on flexible hose.

2.5.2 It is expected that hose assemblies may need to be replaced several times in the life of the ship. Manufacturer's recommendations should be followed in this respect. However, hoses should be replaced as soon as possible whenever there is doubt as to their suitability to continue in service. Test reports of flexible hoses should be kept on board to ensure that correct replacement hoses are used when making repairs.

2.6 Flexible pipes should be closely examined and renewed if signs of material cracking or deterioration are evident. Extra care should be exercised in the tightening of these pipe connections to ensure that they are not twisted when re-installed.

2.7 Flexible pipes should be pressure tested to their original design pressure at five-year intervals. Alternatively, such pipes should be the subject of a study aimed at determining their finite life and then be automatically renewed before that life cycle has been reached. Recommendations of engine and fuel system manufacturers should be sought and considered.

## **3 Bellows expansion joints**

### **3.1 Design**

Expansion joints are designed to accommodate axial and lateral movement. Expansion joints should not be used to compensate for pipe misalignment. Design may be based on an acceptable code or on testing of expansion joints of similar construction, type, size and use. Thermal expansion, contraction and the fatigue life due to vibration are also important points to consider. Where external mechanical damage is possible, the bellows are to be suitably protected. Each bellows expansion joint should be provided with a certificate of hydrostatic pressure testing and conformity of production.

### **3.2 Installation**

The bellows expansion joints should be installed in accordance with the manufacturer's instructions and examined under working conditions.

### **3.3 *Inspection and maintenance***

Bellows expansion joints should be inspected regularly and be replaced whenever there is doubt as to their suitability to continue in service.

## **4 *Filters and strainers***

### **4.1 *Design***

4.1.1 Housings and bodies of filters and strainers used in oil fuel, lubricating oil or other flammable oil systems should be made of steel or other equivalent material with a melting point above 930°C and with an elongation above 12%. Other housing and body materials may be utilized provided their use is specially considered on a case-by-case basis in relation to the risk of fire.

4.1.2 All pressure-retaining parts should be suitable for the design temperature and pressures. The filter or strainer design and construction should facilitate cleaning and prevent or minimize spillage during maintenance.

4.1.3 Plug type air vents are not permitted. Air vent cocks or valves should be clearly marked with open/closed positions and the discharge should be led to a safe position.

4.1.4 Oil residues of drain trap should lead to one of the drain tanks.

### **4.2 *Installation***

Filters and strainers should be located as far away as practicable from hot surfaces and other sources of ignition. They should not be located in positions where spillages could fall onto the flywheel or other rotating machinery parts and be sprayed around. Suitable drip trays should be provided under filters and strainers. A vertical spray shield that will prevent a high pressure fuel or lubricating oil leak from coming into contact with a hot surface should be installed between the strainer and the hot surface. If a hot surface cannot be insulated or the oil filter cannot be located in a safe position, it should be installed in parallel with another filter. The spray shields should be installed in such a manner as to not impede the servicing of the filter or strainer.

### **4.3 *Inspection and maintenance***

Filters and strainers should be inspected every time they are opened for cleaning and the cover gaskets or seals should be renewed when necessary. Satisfactory seating and tightening of the cover should be verified before the system is put back into service. The filter or strainer should also be carefully bled of air before returning the unit into service.

## **5 *Insulation materials***

### **5.1 *Design***

5.1.1 Insulation of high temperature surfaces should be primarily provided to reduce the risk of fire by reducing the temperature of surfaces below 220°C.

5.1.2 Insulation of hot surfaces, in addition to high temperature surfaces should be considered to reduce the potential risk of fire.

5.1.3 The insulation should be non-combustible and so supported that it will not crack or deteriorate when subject to vibration.

## **5.2 *Installation***

Manufacturers' instructions should be followed, if available. Permanent insulation should be used to the greatest extent possible. Insulation should be provided with readily removable sections to allow access for normal maintenance. The surface of any oil-absorbent and oil-permeable insulation should be covered by a material which is impervious to oil or oil vapours.

## **5.3 *Inspection and maintenance***

A regular check of equipment should be made to confirm that the insulation is in place. When maintenance or repair of equipment has been carried out, checks should be made to ensure that the insulation covering the high temperature or hot surfaces has been properly reinstalled or replaced; surface temperature should be measured if considered necessary.

# **6 Pressure, temperature, oil level gauges and sight glasses**

## **6.1 *Design***

All pressure gauges and other similar instruments in oil systems should, wherever possible, be fitted with an isolating valve or cock at the connection to the pressure take off point. The number of pressure take off points should be kept to a minimum and gauge piping runs should be as short as practicable. Copper pipes, where permitted, may be joined by brazing but soldered connections should not be used in oil systems. Temperature gauges in oil systems should be fitted into a fixed pocket (thermo-well). Oil level gauges should be of a design which is approved for the intended service. The glass or equivalent used on oil piping systems, such as sight glasses for overflow pipes of oil tanks, should be of a heat resistant type.

## **6.2 *Installation***

The installation of level gauges that penetrate below the top of oil tanks is prohibited under SOLAS for passenger ships, and is discouraged for cargo ships. Suitably protected gauges having heat resistant flat glass of substantial thickness and self-closing fittings at each tank connection may be fitted with the permission of the Administration to oil tanks in cargo ships. Self-closing fittings should not have locking devices fitted to keep them in the open position. Round gauge glasses are not permitted.

## **6.3 *Inspection and maintenance***

Copper gauge piping is particularly sensitive to work-hardening. All gauge pipes and fittings should be regularly inspected and maintained in good working order.

# **7 Pipe fittings**

## **7.1 *Design***

7.1.1 Materials for valves and pipe fittings should be suitable for the media and service for which the pipes are intended.

7.1.2 All gasket and seal ring materials, and any jointing compounds used, should comply with the requirements of the manufacturer and relevant international standards.

7.1.3 Direct connection of pipe lengths should be made by direct welding, flanges, threaded joints or mechanical joints, and should be of international standards or of a design proven to be suitable for the intended purpose.

7.1.4 All copper and aluminium-brass piping should be heat treated (annealed) and fitted with sufficient supports to prevent damage from vibration. Replacement with steel piping should be considered.

7.1.5 All component locking devices, such as spring and tab washers and locking wires should be present and in use. (It is recognized that it is impracticable to lock fuel pump vent screws with wire, due to their frequent use. However, wire loops containing a weight attached to each screw would prevent them unscrewing under the influence of vibration if they became slack.)

7.1.6 Valves fitted to oil fuel tanks under static pressure should be of steel or spheroidal-graphite cast iron with an elongation of 12% or above.

7.1.7 Ordinary cast iron valves may be used in piping systems where the design pressure is lower than 7 bar and the design temperature is below 60°C.

## **7.2 *Installation***

Pipe fittings, including flanged connections should be carefully tightened without exceeding permissible torque. If necessary, suitable spray shields or sealing tape should be used around flange joints and screwed pipe fittings to prevent oil spraying onto hot surfaces in the event of a leakage.

## **7.3 *Inspection and maintenance***

Where fitted, compression fittings should be carefully examined and, if necessary, tightened (but not over-tightened) with a torque spanner to the manufacturer's specification. Replacement with flanged connections should be considered.

## PART III

### ENGINE-ROOMS

#### CHAPTER 1 – CONTROL OF FLAMMABLE OILS

##### 1 Arrangement and installation of pressurized oil fuel systems

1.1 Major factors which can lead to failures of oil fuel system components are:

- .1 poor installation, especially insufficient care being taken to provide adequate support (pipe brackets, etc.) and lack of attention to thermal expansion and possible machinery movement due to flexible mountings;
- .2 the frequent partial dismantling and reassembly of the system for maintenance purposes;
- .3 the effects of high frequency, short duration pressure pulses generated by the action of the fuel injection pumps, which are transmitted back into the oil fuel supply and spill rails; and
- .4 vibration.

##### 1.2 *The causes of high pressure pulses in the oil fuel supply and spill systems*

1.2.1 The most common fuel injection pumps (monobloc or “jerk” pumps) are comprised of a plunger moving up and down in a barrel which contains ports for fuel to enter and leave. The pump is designed to provide the variable fuel flow required for the engine to operate under fluctuating load or rpm, by adjustment of the plunger delivery stroke. At a point determined by the engine’s fuel requirement, the plunger will uncover the ports and the internal pressures between 80 N/mm<sup>2</sup> and 150 N/mm<sup>2</sup> will be spilled back into the fuel supply and spill piping.

1.2.2 Each injection pump action generates high magnitude spill pressures followed by periods of reduced pressure. The pressure differences accelerate columns of fuel within the piping system and, when combined with the action of the circulating pump relief valve, cavitation and reflected pressure waves can be caused. Cavitation implosions occur quickly, and can induce very short duration pressure pulses in excess of 10 N/mm<sup>2</sup>.

1.2.3 Tests have determined that the magnitude of pressure pulses in the fuel system of a typical medium speed diesel engine installation are greatest at 40% to 60% engine load, and will reach 6 N/mm<sup>2</sup> to 8 N/mm<sup>2</sup>. The pulses are approximately eight times the nominal pressure of the system. High-speed engines, such as those installed on high-speed craft, generate higher injection pressures and it is likely that the fuel system of these engines will experience correspondingly higher pressure pulses.

1.2.4 High pressure pulses lead to vibration and fatigue and are responsible for many failures of equipment such as thermostats, pressostats and mechanical dampers. The failure of fuel lines and their components will invariably involve fatigue and the initiation of fractures due to tensile stress.



### 1.3 *Design consideration*

1.3.1 It is essential that the fuel system is designed to accommodate the high pressure pulses which will be generated by the injection pumps. The engine manufacturer and/or the fuel installation manufacturer and the piping installer, etc., should be consulted for an explicit statement of the fuel system parameters including the maximum pressures which will be generated. Many engine manufacturers, aware of the potential risks due to high pressure pulses within the fuel system, now aim to limit the magnitude of the pulses to  $1.6 \text{ N/mm}^2$  at the engine fuel rail outlets.

1.3.2 The alternative approaches which may be considered by the designer are:

- .1 to design the fuel system such that it is able to contend with the magnitude of pressure pulses generated. Piping systems should be designed and installed to an appropriate classification society or ISO specification;
- .2 to install pressure damping devices; or
- .3 to specify injection pumps which are designed to eliminate or reduce high pressure pulses.

1.3.3 The fuel line between the fuel tank and the engine is made up of several parts often from different suppliers. The fact that these suppliers may be unaware of, and therefore do not take into account, the pressures that may be placed on their equipment by the other components of the system, is often the reason for the system's failure. The specification, design and installation of all of the components of the fuel system should be carefully coordinated to ensure that they are all suitable individually, and in combination with the other components, for the anticipated high pressure pulses.

1.3.4 There are a number of pressure damping devices which have been fitted within fuel systems. Mechanical pressure accumulators and gas filled bellows have both been used however, in some cases, problems of slow response and failure due to fatigue and vibration have been reported.

1.3.5 Fuel pipes should be of steel and supports should be adequate to prevent fatigue due to vibration through the structure from the engines and propellers. The support arrangements should also protect the system from vibration caused by high pressure pulses. Copper and aluminium-brass pipes should not be used as their inherent work hardening characteristics make them prone to failure when subjected to vibration.

1.3.6 Experience indicates that compression couplings require careful attention to tightening procedures and torques to avoid leaks or damage to the pipe when subjected to over-tightening. They should not be used in the fuel supply line of the injection pumps and spill system. Flanged connections should be used in place of compression couplings.

1.3.7 In multi-engine installations supplied from the same fuel source, means of isolating the fuel supply to and spill from individual engines should be provided. The means of isolation should be operable from the control position. Without the ability to isolate the fuel supply and spill lines on each engine a single leak could necessitate the need to stop all engines, thus putting the manoeuvrability of the vessel at risk.

## **1.4 Installation**

1.4.1 One designated person should be responsible for coordinating the initial onboard installation of the complete fuel system.

1.4.2 The coordinator should be able to understand the overall design criteria and ensure that the design intent is fully implemented at the time of installation.

## **1.5 Inspection and maintenance**

1.5.1 The ship safety management system should contain procedures to identify vibration, fatigue, defects, poor components and poor fitting of the fuel system and ensure that proper attention to protecting hot surfaces is maintained. Means, such as check lists should be prepared to ensure that all procedures are followed at major overhauls and that all components, supports, restraints, etc., are refitted on completion of such work. The installed system should be routinely inspected for:

- .1 verification of the adequacy of its supports and the condition of its fittings;
- .2 evidence of fatigue stresses to welded or brazed pipes and connections;
- .3 assessment of the level of vibration present; and
- .4 condition of the lagging or shielding of hot surfaces.

1.5.2 Components of the fuel system should be comprehensively examined, particularly threaded connections, at each dismantling.

1.5.3 Injection pump holding-down bolts should be proved tight by testing with a torque spanner at frequent intervals (not to exceed 3 months).

1.5.4 The supports and retaining devices of the low pressure fuel system should be checked at regular intervals (not to exceed 6 months), to be proved tight and to provide adequate restraint. The lining of such devices should be examined for wear and renewed if they provide insufficient support.

## **2 Spray shields for joints of pressurized flammable oil piping systems**

### **2.1 Application**

Spray shields should be fitted around flanged joints, flanged bonnets and any other flanged or threaded connections of oil fuel and lubricating oil systems having an internal pressure exceeding  $0.18 \text{ N/mm}^2$  which have the possibility of being in contact with potential ignition sources by direct spray or by reflection. The purpose of spray shields is to prevent the impingement of sprayed flammable oils onto a high temperature surface or other source of ignition.

## 2.2 Design and installation

2.2.1 Many types of spray shields are possible to avoid spray at flanged connections. For example, the following may be treated as spray shield:

- .1 thermal insulation having sufficient thickness;
- .2 anti-splashing tape made of approved materials. Caution should be taken to avoid using the anti-splashing tape in areas of high temperature so as to maintain its adhesive characteristics. In case of rewinding of the new tape, the surface area of the tape should be clean and dry; and

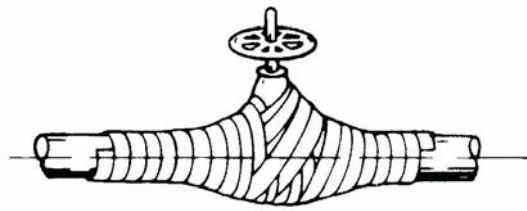

**Figure 3-1 – Example of correct taping method**

- .3 where an anti-spray cover is wrapped around the side of flange, it is not necessary to wrap tightening bolts completely.

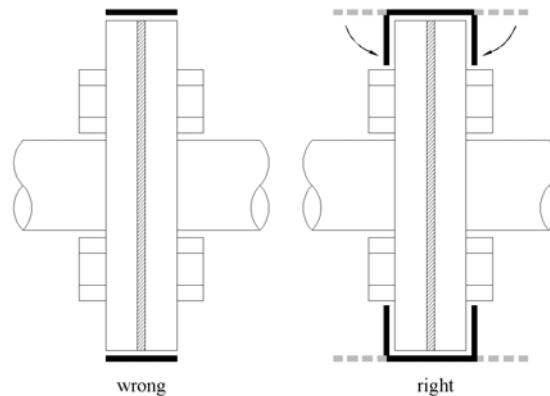

**Figure 3-2 – Recommended arrangement of anti-spray cover for flange joint**

2.2.2 Anti-splashing tape or other equivalent method may be treated as spray shield on threaded connections. Additionally, the use of sealing tape at thread of union joint is strongly recommended to prevent spray.

2.2.3 Spray shields should be applied not only to a piping system but also to pressurized equipment and/or fittings on oil fuel systems, such as heat exchanger, tube plate and filter or strainer body joints.

### 2.3 *Inspection and maintenance*

Spray shields should be inspected regularly for their integrity and any which have been removed for maintenance purposes should be refitted on completion of the task according to the manufacturer's instructions.

## 3 **Jacketed high pressure fuel lines of internal combustion engines**

### 3.1 *Application*

3.1.1 All external high pressure fuel delivery lines between the high pressure fuel pumps and fuel injectors are required to be protected with a jacketed piping system capable of containing fuel from a high pressure line failure.

3.1.2 The requirements are applicable to internal combustion engines installed in any area on board ships irrespective of service and location.

3.1.3 Single cylinder and multi-cylinder engines having separate fuel pumps and those having multiple fuel injection pump units are included.

3.1.4 For the purpose of these Guidelines, lifeboat engines and diesel fire pumps are excluded.

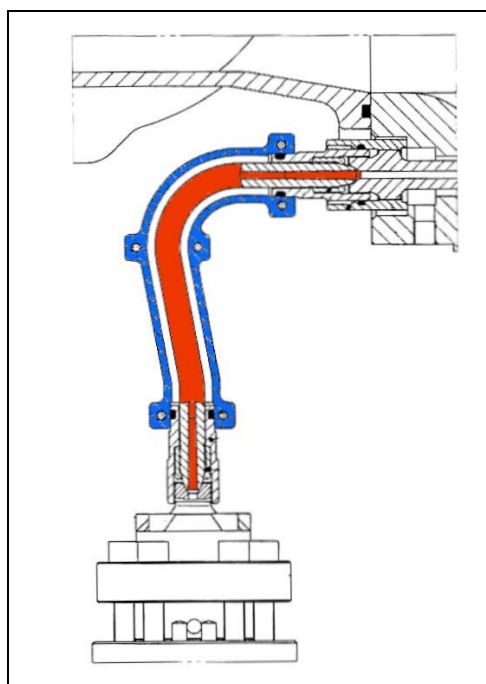

**Figure 3-3 – Sample of jacketed pipe**

### 3.2 *Suitable enclosure*

3.2.1 For engines of less than 375 kW where an enclosure is fitted, the enclosure is to have a similar function to jacketed pipes, i.e. prevent spray from a damaged injector pipe impinging on a hot surface.

3.2.2 The enclosure should completely surround the injection pipes except that existing “cold” engine surfaces may be considered as part of the enclosure.

3.2.3 The enclosure should have sufficient strength and cover area to resist the effects of high pressure spray from a failed fuel pipe in service, prevent hot parts from being sprayed and to restrict the area that can be reached by leaked fuel. Where the enclosure is not of metallic construction, it should be made of non-combustible, non oil-absorbing material.

3.2.4 Screening by the use of reinforced tapes is not acceptable as a suitable enclosure.

3.2.5 Where leaked oil can reach hot surfaces, suitable drainage arrangements should be fitted to enable rapid passage of leaked oil to a safe location which may be a drain tank. Leaked fuel flow onto “cold” engine surfaces can be accepted, provided that it is prevented from leaking onto hot surfaces by means of screens or other arrangements.

3.2.6 Where the enclosure has penetrations to accommodate high pressure fittings, the penetrations should be a close fit to prevent leakage.

### **3.3 *Design***

Two systems have been successfully used in meeting this requirement, namely, rigid sheathed fuel pipe and flexible sheathed fuel pipe. In both systems the sheathing is to fully enclose the pipe and is to resist penetration by a fine spray or jet of oil from a failure in the pipe during service. Also the annular space and drainage arrangements should be sufficient to ensure that in the event of complete fracture of the internal pipe, an excessive build up of pressure cannot occur and cause rupture of the sheath. The suitability of such pipes should be demonstrated by prototype testing. The drainage arrangement should prevent contamination of lubricating oil by oil fuel, and should include an alarm to indicate leakage has occurred.

### **3.4 *Inspection and maintenance***

Regardless of the system selected, little additional maintenance or periodic inspection is required to keep the jacketed fuel lines in proper working order. However, jacketed pipes should be inspected regularly and any drainage arrangement which may have been disconnected for maintenance purposes should be refitted on completion of the task.

## **CHAPTER 2 – CONTROL OF IGNITION SOURCE**

### **1 *Insulation of hot surfaces and high temperature surfaces***

#### **1.1 *Design***

##### **1.1.1 *Insulation practice***

Different insulation methods for high temperature surfaces are possible and their design should be confirmed by relevant Administrations or recognized organizations. Examples of typical insulation practice are shown in figures 3-4 and 3-5 below.

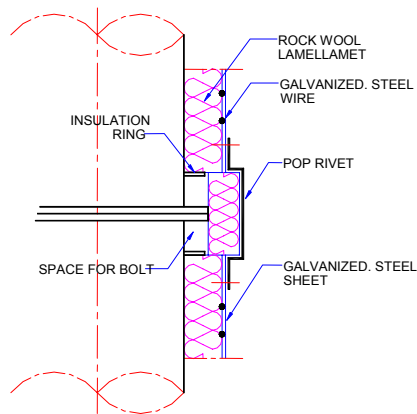

**Figure 3-4 – Insulation method on flanged part**

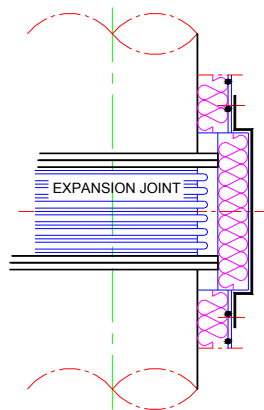

**Figure 3-5 – Insulation method on compensator part**

### 1.1.2 Exhaust gas piping

In order to avoid a discontinuity of insulation of the exhaust gas piping (i.e. the exhaust gas piping before and after turbo charger and the exhaust gas piping between cylinder and exhaust gas manifold), special finishing material (e.g., pop-riveted sheet metal or oil-impervious finish insulation mat) should be used as shown in figure 3-6.

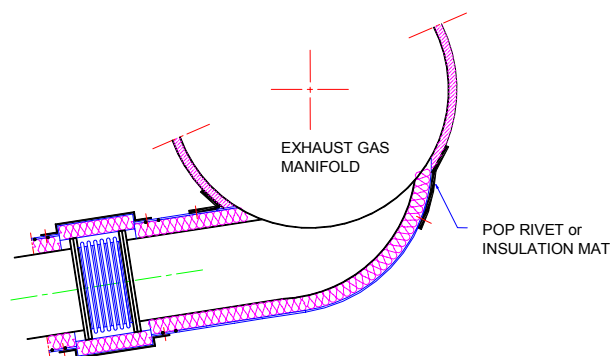

**Figure 3-6 – Insulation practice of discontinuous part**

### 1.1.3 Exhaust gas manifolds

Even though the insulation of the exhaust gas manifold is considered sturdy and satisfactory, special attention should be given to insulating the manifold supports since they are susceptible to become hot surfaces due to heat transfer.

### 1.1.4 Exhaust gas turbo chargers

Dry type turbo chargers, if installed, should be completely insulated, as far as practicable, to prevent the existence of high temperature surfaces.

### 1.1.5 Cylinder head indicator cocks

Exposed indicator cocks should be insulated in order to cover the high temperature surface.

### 1.1.6 Superheated steam pipes

In order to avoid a discontinuity of insulation of superheated steam piping, special finishing material, e.g., pop-riveted sheet metal cladding or oil-impervious finish insulation mat, should be used.

## 1.2 *Inspection and maintenance*

1.2.1 A regular check of equipment or material should be made to confirm that the insulation is correctly installed. When maintenance or repair to equipment has been carried out, checks should be made to ensure that the insulation covering the heated surfaces has been properly reinstalled or replaced. Special attention should be paid to the following:

- .1 insulation areas where vibration may be present;
- .2 discontinuous part of exhaust gas piping and turbo charger; and
- .3 other suspect parts.

## 2 **Protection of electrical equipment**

### 2.1 *Design and installation*

2.1.1 Electrical equipment should be installed in well ventilated and adequately lit spaces in which inflammable gases cannot accumulate and where they are not exposed to the risk of damage from flammable oils.

2.1.2 Switchboards should be installed in dry places away from the vicinity of flammable oil pipes.

2.1.3 Cables fitted in any space where flammable oils or gases may accumulate should have a metallic sheath or an impervious sheath.

2.1.4 Where cables are installed in bunches, and the risk of fire propagation is considered high, special precautions should be taken in cable installation to prevent fire propagation.

### **3 Identification and protection of potential ignition sources**

3.1 While oil impingement on uninsulated hot surfaces has been known to start fires simply due to the vapour reaching its auto-ignition temperature, the hazard is even greater if there is the presence of a flame, spark, naked light bulb, or electric arc.

3.2 The major sources of the above that exist in engine-rooms are as follows:

- .1 cylinder head indicator cocks of internal combustion engines;
- .2 connections of burner assemblies used for boilers, incinerators and inert gas generators;
- .3 electrical panels fitted with magnetic contactors, etc., which undergo repetitive ON/OFF operation during the machinery operation such as purifier control and air compressor panels;
- .4 moving parts subject to relative motion which may lead to metal to metal contact; and
- .5 drain cocks of exhaust gas pipes.

3.4 In case of a flammable oil line located near any of the above ignition sources, it is necessary to carefully consider the probability of spray, possible spray direction, spray distance, etc., and to isolate the ignition sources as far as practicable.

## **CHAPTER 3 – CONTROL OF VENTILATION**

### **1 Design of ventilation systems**

1.1 The ventilation of machinery spaces should be sufficient under normal conditions to prevent accumulation of oil vapour.

1.2 To control and minimize the hazards from the spread of smoke, means for controlling smoke in machinery spaces should be provided.

1.3 Suitable arrangements should be available to permit the release of smoke, in the event of fire, from machinery spaces of category A. Reversible ventilation systems may be acceptable for this purpose.

1.4 The position of fire detectors should be determined with due regard to the ventilation characteristics of the space.



## CHAPTER 4 – USEFUL ARRANGEMENT, INSTALLATION AND APPARATUS FOR FIRE SAFETY

### 1 Measures for the prevention of spillage of flammable oils

#### 1.1 Tanks

1.1.1 Tanks used for the storage of fuel oil, lubricating oil, hydraulic oil, thermal oil and other flammable oils, together with their fittings, should be constructed so as to prevent overpressure and spillages due to leakage or overfilling.

1.1.2 An alarm device should be provided to give warning when the oil reaches a predetermined level in the tank or, alternatively, a sight glass should be provided in the overflow pipe to indicate when any tank is overflowing. Such sight glasses should be placed on vertical pipes only, in readily visible positions, and should be shown by testing to have a suitable degree of fire resistance.

1.1.3 Any overflow pipe should have a sectional area of at least 1.25 times that of the filling pipe and should be led to an overflow tank of adequate capacity or to a storage tank having space reserved for overflow purposes.

#### 1.2 Air and overflow pipes

1.2.1 Air pipes from oil fuel tanks and heated lubricating oil tanks should be led to a safe position on the open deck. They should not terminate in any place where a risk of ignition is present. Air pipes from unheated lubricating oil tanks may terminate in the machinery space, provided that the open ends are so situated that issuing oil cannot come into contact with electrical equipment, heated or hot surfaces.

1.2.2 Any overflow pipe should have a sectional area of at least 1.25 times that of the filling pipe and should be led to an overflow tank of adequate capacity or to a storage tank having space reserved for overflow purposes.

1.2.3 In order to fulfil the requirements of SOLAS regulation II-1/26.11, a common air pipe is commonly used. In this case the air pipes from heated and unheated oil tanks should be separated.

#### 1.3 Measuring devices of tanks

1.3.1 Where sounding pipes are used, they should not terminate in any space where the risk of ignition of spillage from the sounding pipe might arise. In particular, they should not terminate in passenger or crew spaces. As a general rule, they should not terminate in machinery spaces. However, where the classification society considers that these latter requirements are impracticable, it may permit termination of sounding pipes from tanks in machinery spaces, on condition that all of the following requirements are met:

- .1 an oil level gauge of an approved type is provided;
- .2 the sounding pipes terminate in locations remote from ignition hazards, unless precautions are taken such as the fitting of effective screens to prevent the oil fuel in the case of spillage from the sounding pipes, coming into contact with a source of ignition; and

- .3 the terminations of sounding pipes are fitted with self-closing blanking devices and with a small-diameter self-closing control cock located below the blanking device for the purposes of ascertaining before the blanking device is opened that oil fuel is not present. Provision should be made so as to ensure that any spillage of oil fuel through the control cock involves no ignition hazard. Locking arrangements for self-closing blanking devices to be kept in the open position should not be permitted.

1.3.2 Short sounding pipes may be used for tanks, other than double bottom tanks, without the additional closed level gauge provided an overflow system is fitted.

1.3.3 Oil level gauges may be used in place of sounding pipes, subject to the following conditions:

- .1 in passenger ships, such gauges should not require penetration below the top of the tank and their failure or overfilling of the tanks will not permit release of fuel; and
- .2 in cargo ships, the failure of such gauges or overfilling of the tank should not permit release of fuel. The use of cylindrical gauge glasses is prohibited. The classification society may permit the use of oil-level gauges with flat glasses and self-closing valves between the gauges and fuel tanks.

## **2 Fuel oil isolation valves for multi-engines**

2.1 In order to fulfil SOLAS regulation II-2/4.2.2.5.5, isolating valves should be located and operable from a position not rendered inaccessible by a fire on any of the engines.

2.1.1 Where practicable, isolating valves should be located at least 5 m away from engines in any direction. If this is not possible, the operating position of the valves should be protected by an obstruction. Figure 3-8 shows an example of protection by obstructions.

2.1.2 If the above is impracticable, other means of protection capable of enabling access to the isolating valves in the event of a fire might be acceptable.

2.1.3 Figure 3-9 shows the possible areas affected by fire and figure 3-10 shows a schematic diagram of a typical isolation valve arrangement.

2.1.4 Isolating valves controlled remotely could be acceptable. In this case, the operating mechanism should be protected from fire.

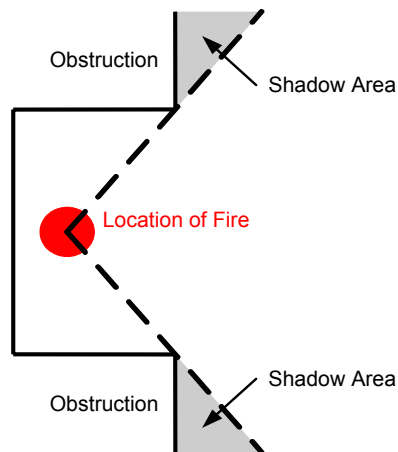

Figure 3-8 – Safe isolating valve operating position protected by obstruction

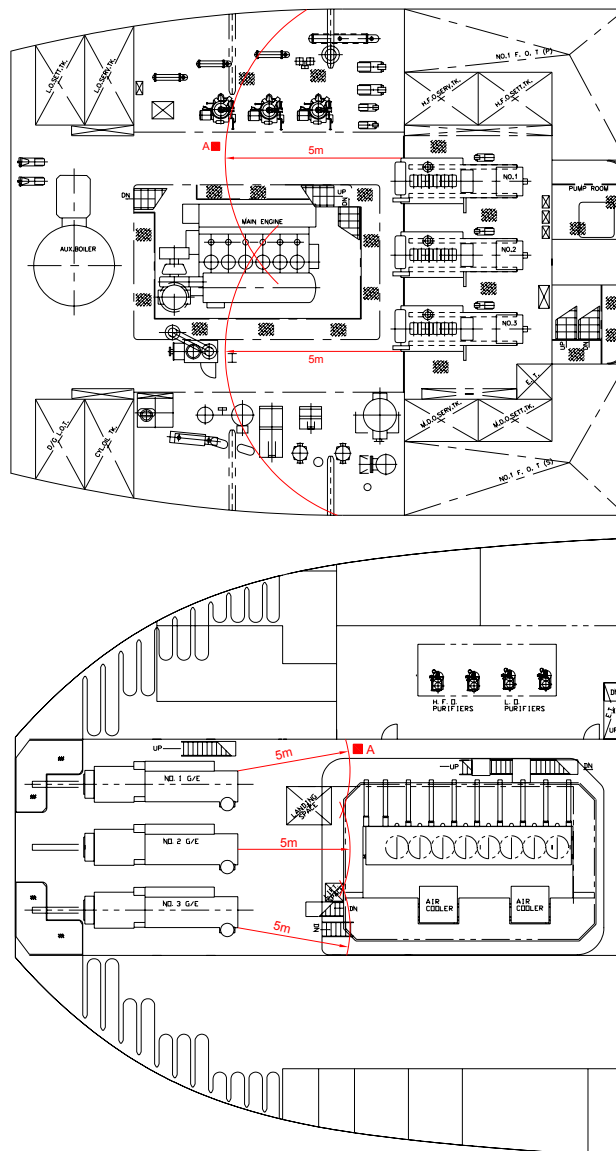
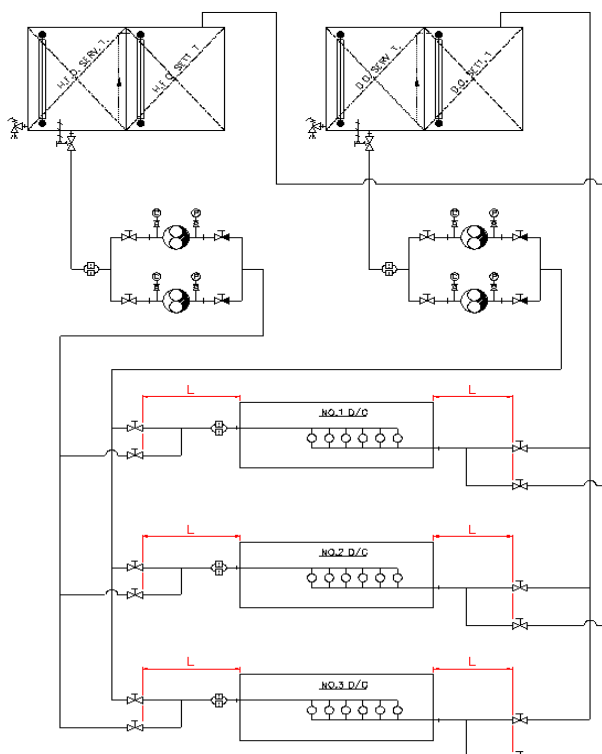

Figure 3-9 – Isolation valves arrangement for multi-engines



**Figure 3-10 – Acceptable arrangement of isolation valves**

## CHAPTER 5 – EQUIPMENT INSTALLATION

### 1 Boilers

#### 1.1 System arrangement

1.1.1 Boilers should be suitably insulated with non-combustible material and sheathed with steel or other non-combustible material the surface of which is to be impervious to oil and oil vapours. The clearance spaces between the boilers and tops of double bottom tanks, and between the boilers and the sides of storage tanks in which oil fuel and cargo oil is carried, should be adequate for the free circulation of air necessary to keep the temperature of the stored oil sufficiently below its flashpoint, except in the case of tanks not heated to temperatures within 10°C below the flashpoint of the fuel oil.

1.1.2 The oil burning units should meet the following requirements:

- .1 oil burners should be so arranged that they cannot be withdrawn unless the oil supply to the burners is cut off; and
- .2 fuel supply to all burners should be capable of being automatically cut off in case of total lack of flame in the combustion chamber; moreover, this should be warned by a visual and audible alarm. The alarms need not be fitted for domestic boilers.

1.1.3 Where boilers are located in machinery spaces on 'tween decks and the boiler rooms are not separated from the machinery space by watertight bulkheads, the 'tween decks should be provided with coamings at least 200 mm in height. This area may be drained to the bilges. The drain tank should not form part of an overflow system.

## **2 Thermal oil installations**

### **2.1 System arrangement**

2.1.1 The inlet and outlet valves of oil-fired thermal oil heaters and exhaust-fired thermal oil heaters should be controllable from outside the compartment where they are situated. As an alternative, an arrangement for quick gravity drainage of the thermal oil contained in the system into a collecting tank is acceptable.

2.1.2 Heating of liquid cargoes with flashpoints below 60°C should be arranged by means of a separate secondary system, located completely within the cargo area. However, a single circuit system may be accepted on the following conditions:

- .1 the system is so arranged that a positive pressure in the coil should be at least 3 m water column above the static head of the cargo when circulating pump is not in operation;
- .2 the thermal oil system expansion tank should be fitted with high and low level alarms;
- .3 means should be provided in the thermal oil system expansion tank for detection of flammable cargo vapour. Portable equipment may be accepted; and
- .4 valves for the individual heating coils should be provided with locking arrangement to ensure that the coils are under static pressure at all times.

2.1.3 The thermal oil circulating pumps should be arranged for emergency stopping from a position outside the space where they are situated.

2.1.4 Vents from expansion tanks and thermal oil storage tanks of thermal oil heating plants should be led to open deck.

### **2.2 Exhaust-fired thermal oil heaters**

2.2.1 The heater should be so designed and installed that all tubes may easily and readily be inspected for signs of corrosion and leakage.

2.2.2 Visual inspection and tightness testing of the heater tubes to not less than the working pressure should be carried out annually, and hydraulic testing should be carried out bi-annually.

2.2.3 The heater should be fitted with temperature sensor(s) and an alarm for fire detection.

2.2.4 A fixed fire-extinguishing and cooling system should be fitted. A drenching system providing at least 5 l/m<sup>2</sup>/min of water may be accepted. The exhaust ducting below the exhaust boiler should be arranged for adequate collection and drainage, to prevent water flowing into the diesel engine. The drain should be led to a suitable location.

### **3 Purifier rooms**

#### **3.1 System arrangement**

3.1.1 As far as practicable, purifiers and associated components should be placed in a separate room, enclosed by bulkheads having effective construction and rooms should be provided with:

- .1 independent mechanical ventilation or a ventilation arrangement which can be isolated from the machinery space ventilation; and
- .2 fire-detecting and fire-extinguishing systems.

3.1.2 If it is impracticable to locate the main components in a separate room, the purifiers and associated components should be located in a space which is equipped with the following:

- .1 Scuppers having sufficient capacity to minimize the free surface of oil. Where drain pipes are provided from collected leakages, they should be led to a suitable oil drain tank not forming part of an overflow system.
- .2 Spray shields in way of any connections of flammable oil pipes; any leakage should be led to scuppers.

3.1.3 The control panel should be located in an area in which flammable mist cannot accumulate.

### **4 Oil heaters**

#### **4.1 System arrangement**

4.1.1 Where steam heaters or heaters using other heating media are provided in fuel or lubricating oil systems, they should be fitted with at least a high temperature alarm or low flow alarm in addition to a temperature control, except where the temperature limit for the ignition of the medium cannot be reached.

4.1.2 When electric heaters are fitted, means should be provided to ensure that heating elements are permanently submerged during operation. In order to avoid a heating element surface temperature of 220°C and above, a safety temperature switch, independent from the automatic control sensor, should be provided. The safety switch should cut off the electrical power supply in the event of excessive temperature and should be provided with a manual reset.

4.1.3 Containment enclosures should be fitted with adequate drainage. Where drain pipes are provided from collected leakages, they should be led to a suitable oil drain tank not forming part of an overflow system.

### **5 Hydraulic power packs**

#### **5.1 System arrangement**

5.1.1 Hydraulic power packs of more than 50 kW with a working pressure more than 100 bar should be installed in specially dedicated spaces, with a separate ventilation system.

## PART IV

### CARGO PUMP-ROOMS

#### CHAPTER 1 – CONTROL OF FLAMMABLE MATERIALS

##### 1 General

1.1 Requirements described below should be applied to vessels carrying oils with flashpoints not exceeding 60°C (closed cup test).

1.2 Alternative design and arrangements might be acceptable, if new design meets SOLAS regulation II-2/17.

##### 2 Equipment and fittings on cargo piping systems

###### 2.1 *Materials*

2.1.1 Aluminium pipes should be prohibited except those used in ballast tanks and inerted cargo tanks.

###### 2.2 *Piping arrangement and design*

2.2.1 In order to avoid the generation of static electricity when cargo is loaded directly into tanks, the loading pipes, as far as practicable, should be led to the lowest area in the tank.

2.2.2 Spray shields or spray protection covers should be provided on any detachable connections and around the glands of cargo handling pumps in order to reduce the formation of mist.

#### CHAPTER 2 – CONTROL OF IGNITION SOURCE

##### 1 General

1.1 The steam and heating media temperature within the cargo area should not to exceed 220°C.

1.2 Any potential ignition sources should be protected.

##### 2 Lighting system and protection of electrical equipment

2.1 Glazed port lights providing illumination to the pump-rooms should be effectively protected from mechanical damage by strong covers secured from the side of the safe space.

2.2 Lighting other than emergency lighting should be interlocked with ventilation.

##### 3 Protection of penetration to other spaces

3.1 Any penetration of the engine-room boundary or safety area passing through a pump-room bulkhead should be provided with the following:

- .1 gas tight sealing device with efficient lubricant (periodic greasing type is not permitted); and
- .2 temperature measuring device.

## **4 Temperature monitoring system for pumps in cargo pump-rooms**

### **4.1 *Design requirements***

4.1.1 Except for pump-rooms intended solely for ballast transfer or fuel oil transfer, temperature monitoring systems for pumps should be provided.

4.1.2 The following pumps installed in cargo pump-rooms, which may be driven by shafts passing through pump-room bulkheads, are included:

- .1 cargo pumps including slop pumps;
- .2 ballast pumps;
- .3 stripping pumps; and
- .4 tank cleaning pumps.

4.1.3 The following pumps might be omitted:

- .1 small pumps of 1 m<sup>3</sup>/h capacity or less; and
- .2 bilge pumps.

### **4.2 *System arrangements***

4.2.1 Sensing points should be provided as follows:

- .1 bulkhead shaft glands;
- .2 bearings; and
- .3 pump casings.

4.2.2 In case of parallel bearing support with common oil bath, only one bearing sensor might be installed.

4.2.3 The range of temperature for sensors is recommended to be from 0°C to 250°C and the setting point to about 60°C to 80°C in consideration to the kind of pumps, cargoes and environmental condition, which would automatically shut down the pump when the set point is reached.

4.2.4 Sensors should be installed so that the end of sensor reaches the measuring points and is fixed permanently.



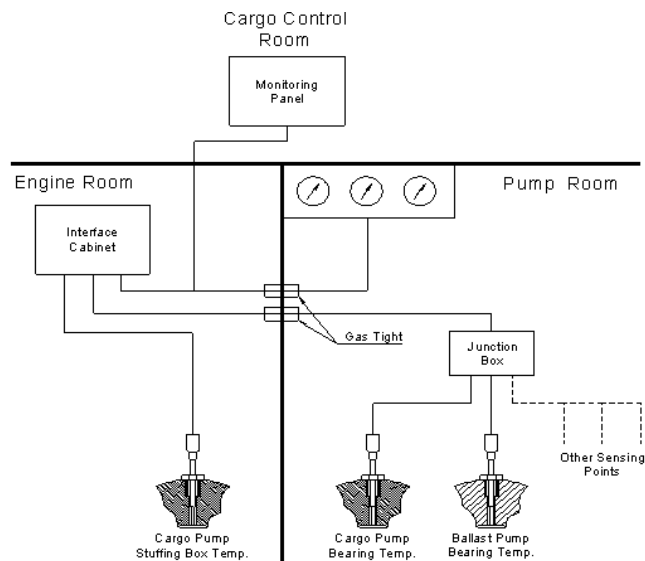

**Figure 4-1 – Sample of temperature monitoring system**

## CHAPTER 3 – CONTROL OF VENTILATION

### 1 Design criteria of ventilation systems

- .1 cargo pump-rooms should be mechanically ventilated and the capacity should be 20 air changes per hour of the total volume of the pump-room;
- .2 the position of the vent outlet should be arranged at a distance of at least 3 m measured horizontally from any ignition source and from the nearest opening to accommodation, service or machinery spaces;
- .3 an emergency intake located about 2 m above the pump-room lower grating is to be provided. This emergency intake is to be used when the lower intake is sealed off due to flooding in the bilges. The emergency intake should have a damper fitted which is capable of being closed from the exposed main deck and lower grating level;
- .4 floor gratings should not disturb the free flow of air; and
- .5 normally, the density of petroleum product vapours are heavier than air (x 2), however, the density of diluted gas/air mixture is closer to air (x 1.5). Therefore, vapour density and pump-room temperature should be carefully considered for the design of the ventilation arrangement.

### 2 Gas detection systems

#### 2.1 Design requirements

- .1 sampling lines should not run through gas-safe spaces;
- .2 gas analysing units located in dangerous areas should be of the explosion-proof type;

- .3 gas sampling pipes should be equipped with flame arresters;
- .4 sampling points should be located in zones where air circulation is reduced (dead spots such as recessed corners);
- .5 the following should be considered in selecting hydrocarbon gas detector and detection positions in cargo pump-rooms:
  - .5.1 shape of the cargo pump-room; and
  - .5.2 placement of exhaust duct considering the flow characteristics;
- .6 if necessary, actual demonstration tests or computational simulation analysis should be carried out;
- .7 a hydrocarbon gas detector is recommended to be installed in the following places:
  - .7.1 (perpendicular) upper part of the main cargo pump or between two cargo pumps;
  - .7.2 one detector within 30 cm above the lowest part of the cargo pump-room bottom floor; and
  - .7.3 one detector every 10 m length or width of the cargo pump-room;
- .8 sequential sampling is acceptable as long as it is dedicated to the pump-room, including exhaust ducts, and if the sampling time is reasonably short;
- .9 sample gas should be provided with or connected to the analysing unit for regular calibration, otherwise calibration records carried out by a specialist should be kept on board; and
- .10 sampling tubing should be resistant to water and cargo vapour.

## **2.2 *The setting value***

- .1 audible and visual alarms should be activated by the hydrocarbon gas with the concentration of a pre-set level which is no higher than 10% of the lower flammable limit (LFL);
- .2 the setting value should be set carefully, because LFL of a mixture of hydrocarbon gases changes according to their mixing ratio;
- .3 in the case of a ship carrying two or more cargoes, the set value of an alarm point should be corrected based on the lowest LFL of each cargo, and the following information and equipment should be provided:
  - .1 LFL data of cargo from shippers, etc.; and
  - .2 gas detectors with function to allow adjustment of the alarm setting.

### 2.3 System arrangement

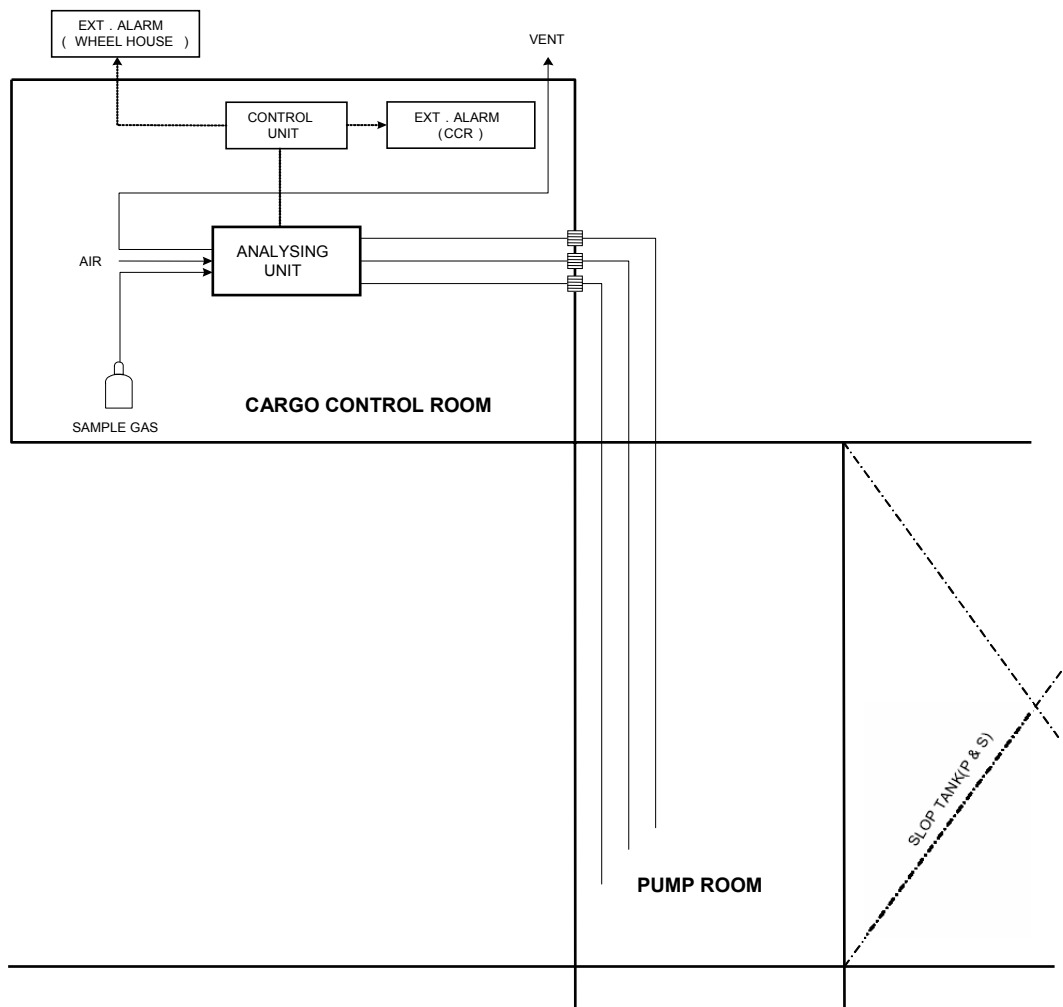

**Figure 4-2 – Monitoring system of the concentration of hydrocarbon gases**