



COMDTPUB P16700.4
NVIC 1-09, CHANGE 1
AUGUST 18, 2018

NAVIGATION AND VESSEL INSPECTION CIRCULAR NO. 1-09, CHANGE 1

Subj: VOLUNTARY COMPLIANCE WITH INTERNATIONAL SEWAGE REGULATIONS IN ANNEX IV TO MARPOL 73/78

- Ref:
- (a) Regulations for Prevention of Pollution by Sewage from Ships, Annex IV to MARPOL 73/78, adopted by MEPC.115(51) on April 1, 2004.
 - (b) Effluent Standards and Performance Tests for Sewage Treatment Plants, adopted by MEPC.159(55) on October 13, 2006.
 - (c) Specifications for Environmental Testing for Type Approval of Pollution Prevention Equipment, Annex: Part 3, adopted by MEPC.107(49) on July 18, 2003.
 - (d) Standards for the Rate of Discharge of Untreated Sewage from Ships, adopted by MEPC.157(55) on October 13, 2006.
 - (e) Marine Sanitation Devices, 33 Code of Federal Regulations Part 159
 - (f) Amendments relating to the adoption of Special Area Provisions and the Designation of the Baltic Sea as a Special Area adopted by MEPC.200(62) adopted on July 15, 2011.
 - (g) Specifications for the Testing of Effluent Standards and Performance Tests for Sewage Treatment Plants, adopted by MEPC.227(64) on October 5, 2012.
 - (h) Notice of Policy; 80 FR 62552, October 16, 2015

1. **PURPOSE.** This circular revises Navigation and Vessel Inspection Circular (NVIC) 1-09 and incorporates changes made by references (f) and (g) to provide additional guidance for vessel owners or operators as well as manufacturers of any shipboard sewage processing equipment, including facilities that test shipboard sewage and related processing equipment, to voluntarily request U.S. Coast Guard certification of compliance with international sewage regulations in Annex IV to MARPOL 73/78. It also provides for reciprocity under Annex IV for non-U.S. flagged ships operating in waters subject to the jurisdiction of the United States.

DISTRIBUTION – SDL No. 152

	a	b	c	d	e	f	g	h	i	j	k	l	m	n	o	p	q	r	s	t	u	v	w	x	y	z
A																										
B	4	2	2											1												
C					2								1												2	
D												1*						1								
E					1									1	1			1								
F																										
G																										
H																										

NON-STANDARD DISTRIBUTION: D:I ABS Americas, MARAD, MSC; Special Mailing List: CG-1, CG-10;

NAVIGATION AND VESSEL INSPECTION CIRCULAR NO. 1-09, CHANGE 1

2. ACTION. Area, District, and Sector Commanders, Commanders of Maintenance and Logistics Commands, Commander Deployable Operations Group, Commanding Officers of Headquarters units, Assistant Commandants for directorates, Judge Advocate General, and special staff offices at Headquarters shall ensure that the provisions of this circular are followed. Internet release is authorized.
3. DIRECTIVES AFFECTED. Navigation and Vessel Inspection Circular No. 1-09 is superseded.
4. BACKGROUND.
 - a. The Marine Environment Protection Committee (MEPC) of the International Maritime Organization (IMO) revised MARPOL Annex IV several times over the last decade resulting in several changes to the international regulations governing discharge of sewage from ships on international voyages. More recently, provisions were enacted for the establishment of the Baltic Sea as a Special Area to address the discharge of nitrogen and phosphorous from passenger ships. Associated with this, testing effluent for nitrogen and phosphorous for both new and existing passenger ships operating in Special Areas was included. Additionally, standards for discharging treated sewage into the water were made more stringent and equipment testing procedures were standardized and enhanced to include accounting for dilution water.
 - b. The above mentioned provisions affecting MARPOL Annex IV have been implemented through the following MEPC resolutions:
 - (1) On July 15, 2011, resolution MEPC.200(62) in reference (f) adopted Special Area Provisions and the Designation of the Baltic Sea as a Special Area under MARPOL Annex IV.
 - (2) On October 5, 2012, resolution MEPC.227(64) in reference (g) adopted the *2012 Guidelines on implementation of effluent standards and performance tests for sewage treatment plants*, the text of which is set out in the annex to resolution MEPC.227(64). Applicability of this resolution is outlined in Section 6.a.
 - c. MARPOL Annex IV (resolution MEPC.200(62)) requires accounting for dilution water during the processing of sewage. Additionally, a sewage treatment plant installed on a passenger ship intending to discharge sewage effluent in special areas must meet additional effluent requirements for the removal of nitrogen and phosphorus. This creates a potential for adverse port State control action (e.g., detention) to be taken against U.S. registered vessels engaged in international voyages. Specific compliance dates for these new requirements are detailed in section 6 of this circular.
5. DISCUSSION.
 - a. MARPOL Annex IV requires certain ships that engage in international voyages to have a valid International Sewage Pollution Prevention Certificate (ISPPC) issued by its flag Administration or by a recognized organization acting on behalf of the flag Administration. Under the provisions of Annex IV, an ISPPC cannot be issued to a ship unless its flag State is party to the annex.

NAVIGATION AND VESSEL INSPECTION CIRCULAR NO. 1-09, CHANGE 1

- b. The United States is not party to MARPOL Annex IV. U.S. vessels that engage in international voyages with sewage systems in compliance with Annex IV may be eligible instead to receive a Statement of Voluntary Compliance (SOVC). This certificate takes the place of the ISPPC and is issued to a U.S. vessel by the U.S. Coast Guard or by an Authorized Classification Society (ACS), as appropriate, to demonstrate voluntary compliance with MARPOL Annex IV. The owner or operator of a U.S. vessel subject to requirements of MARPOL Annex IV, while not compelled to obtain a SOVC, may obtain one. Vessels without a valid ISPPC or SOVC on or after January 1, 2010, risk being detained overseas by a port State while operating in waters subject to its jurisdiction.
- c. MARPOL Annex IV prohibits discharge of sewage into the sea except when the ship has in operation an approved *sewage treatment plant*, or is discharging comminuted and disinfected sewage using an approved system at a distance of more than three nautical miles from the nearest land, or is discharging sewage which is not comminuted or disinfected at a distance of more than 12 nautical miles from the nearest land. The term *sewage* is defined by reference (a) to include drainage and other wastes from toilets and urinals, drainage from medical premises including wash basins, wash tubs, and scuppers located in such premises, drainage from spaces containing live animals, and other waste waters when mixed with any of these drainages.
- d. Regulation 9 of MARPOL Annex IV recognizes three different classes of sewage systems.
 - (1) The first class of system is a *sewage treatment plant*. This is a system approved by the flag Administration to comply with the standards and test methods established by the IMO. *Sewage treatment plants* continuously discharge their treated effluent so long as it is not within a special regulated area. In the United States, existing U.S. Coast Guard Type I and Type II MSDs most closely align as *sewage treatment plants* as they may discharge their treated sewage effluent directly into the waterway unless on a body of water where such discharges are otherwise prohibited (e.g., no discharge zones). The more stringent effluent requirements established for new installations of *sewage treatment plants* on or after January 1, 2010, or keel laid dates on or after that date, will invalidate the U.S. Coast Guard's existing equivalency arguments for Type I and Type II MSDs. For ships with approved Type I or Type II MSDs not undergoing installation of a new sewage system, such ships may continue to use such devices as an Administration-approved sewage treatment plant; however passenger ships operating in MARPOL Annex IV Special Areas would not be able to continue to use such devices. This is because these systems are not type approved as to provide a level of equivalency that could be considered as complying with the recent requirements limiting discharge of phosphorous and nitrogen when operating within MARPOL Annex IV Special Areas. Passenger ships operating within MARPOL Annex IV Special Areas are required to limit their discharge of phosphorous and nitrogen as prescribed in resolution MEPC.227(64).
 - (2) The second class of system recognized by MARPOL Annex IV is a *sewage comminuting and disinfecting system with holding tank* approved by the flag Administration. This type of system *must include a holding tank* for the temporary storage of treated sewage when the ship is less than three nautical miles from land. Ships utilizing a comminuter system are prohibited from discharging treated sewage effluent *within three nautical miles* from land. Type II MSDs equipped with a storage tank align closely with this type of system.

NAVIGATION AND VESSEL INSPECTION CIRCULAR NO. 1-09, CHANGE 1

Beginning in 2010, U.S. Coast Guard certified Type II MSDs that are unable to meet the new effluent standards for a *sewage treatment plant* may still qualify as a *sewage comminuting and disinfecting system* provided it is equipped with a satisfactorily sized storage tank.

- (3) The third type of system recognized by MARPOL Annex IV is a *sewage holding tank* and this most closely aligns with the U.S. Coast Guard holding tank requirements for Type III MSDs.
 - e. In the United States, a “sewage treatment plant” is referred to as a “marine sanitation device” (MSD) and while both systems may perform similar functions, the two terms are distinct in application. Use sewage treatment plant when referring to equipment under the international regulations contained in MARPOL Annex IV and use MSD when referring to equipment under the U.S. regulations contained in 33 CFR Part 159.
6. PROCEDURE. This circular establishes revised guidance for requesting U.S. Coast Guard certification of voluntary compliance with MARPOL Annex IV. These guidelines are divided into four distinct sections covering general applicability, testing facilities, equipment manufacturers, and the issuance of vessel certificates.
- a. Applicability.
 - (1) MARPOL Annex IV *is applicable to ships on international voyages* that are:
 - (a) ≥ 400 GT; or
 - (b) < 400 GT certified to carry >15 persons, which includes both passengers and crew.
 - (2) The effluent standards and performance tests contained in resolution MEPC.227(64) *with the exception of the requirements in section 4.2* are applicable to *sewage treatment plants installed* on or after January 1, 2016 on:
 1. ships, other than passenger ships, in all areas; and
 2. passenger ships outside MARPOL Annex IV special areas.
 - (3) The effluent standards and performance tests contained in resolution MEPC.227(64) *including the requirements in section 4.2* are applicable to *sewage treatment plants installed* on or after January 1, 2016 on:
 1. new passenger ships when operating in a MARPOL Annex IV special area and intending to discharge treated sewage effluent into the sea on or after January 1, 2016; and
 2. existing passenger ships when operating in a MARPOL Annex IV special area and intending to discharge treated sewage into the sea on or after January 1, 2018.

NAVIGATION AND VESSEL INSPECTION CIRCULAR NO. 1-09, CHANGE 1

- (4) The effluent standards and performance tests contained in resolution MEPC.159(55) are applicable to *sewage treatment plants* installed prior to January 1, 2016 and on or after January 1, 2010, on ships other than passenger ships operating in MARPOL Annex IV special areas and intending to discharge treated sewage effluent into the sea.¹
- (5) Sewage treatment plants installed prior to January 1, 2010, on ships other than passenger ships operating in MARPOL Annex IV special areas and intending to discharge treated sewage effluent into the sea may continue to use equipment certified to either the 1976 international effluent standards contained in resolution MEPC.2(VI) or an applicable national specification. In the United States, this applicable national specification is 33 CFR Part 159.
- b. Testing Facility. Enclosure (1) contains guidance for testing facilities to be accepted by the U.S. Coast Guard as a *qualified facility* and includes the performance testing protocols for each type of sewage system.
- c. Equipment Manufacturer. Enclosure (2) contains guidance for equipment manufacturers to request a Certificate of Approval from the U.S. Coast Guard.
- d. Vessel Certificates. Enclosure (3) contains guidance for owners or operators of vessels that engage in international voyages to request a Statement of Voluntary Compliance (SOVC) with MARPOL Annex IV from the U.S. Coast Guard.
- e. Special Circumstances. MARPOL Annex IV may be applicable to vessels other than inspected vessels, including small tugs, recreational boats, yachts, etc., that engage in international voyages. Regulation 4 in MARPOL Annex IV requires a flag Administration to establish appropriate measures for vessels not specifically subject to international sewage regulations. In this case, for U.S. vessels and other vessels subject to the jurisdiction of the United States, appropriate measures are provided for under 33 CFR Part 159 in reference (e). U.S. vessels intending to engage in international voyages may apply for a SOVC using the procedures in enclosure (3).
- f. Reconsideration. If a vessel owner, laboratory official, or manufacturer's representative does not agree with a U.S. Coast Guard decision directly related to any provision of this NVIC, a reconsideration of that decision may be submitted to the office responsible for implementing this guidance listed under Contact Information at the end of enclosures (1) through (3). The procedures in 46 CFR 1.03 may be followed when submitting a request for reconsideration.

¹ From IMO Unified Interpretation to Resolution MEPC.159(55) (see document MEPC 56/23)

“For application of resolution MEPC.159(55), the phrase “*installed on board a ship on or after 1 January 2010*” shall be interpreted as follows:

(a) For new ships, installations on board ships the keels of which are laid or which are at a similar stage of construction on or after 1 January 2010.

(b) For existing ships, new installations with a contractual delivery date to the ship on or after 1 January 2010 or, in the absence of a contractual delivery date, the actual delivery of the equipment to the ship on or after 1 January 2010.”

NAVIGATION AND VESSEL INSPECTION CIRCULAR NO. 1-09, CHANGE 1

7. DISCLAIMER. This guidance is not a substitute for applicable legal requirements, nor is it itself a rule. It is not intended to nor does it impose legally-binding requirements on any party. It represents the Coast Guard's current thinking on this topic and may assist industry, mariners, the general public, and the Coast Guard, as well as other federal and state regulators, in applying statutory and regulatory requirements. You can use an alternative approach for complying with these requirements if the approach satisfies the requirements of the applicable statutes and regulations. If you want to discuss an alternative approach (you are not required to do so), you may contact the office responsible for implementing this guidance listed under Contact Information at the end of enclosures (1) through (3).
8. CHANGES. This circular is available on the Web at <http://www.uscg.mil/hq/cg5/nvic/>. The Coast Guard will issue and post time sensitive amendments as an urgent change message on its Website for the benefit of the industry. Interested parties may suggest improvements to this circular by writing to the office responsible for implementing this guidance listed under Contact Information at the end of enclosures (1) through (3).
9. ENVIRONMENTAL ASPECT AND IMPACT CONSIDERATIONS. This NVIC falls within USCG Categorical Exclusion L5 (from the requirement, under 42 USC § 4332(C) to provide a detailed statement of the environmental impact of promulgating the NVIC) because the NVIC is intended to provide guidance to implement, without substantive change, requirements of MARPOL Annex IV, so as to enable US-flagged ships to enter waters subject to the jurisdiction and control of State Parties to MARPOL Annex IV without risking adverse port State control action by such Party States for failure to demonstrate compliance with MARPOL Annex IV.
10. FORMS/REPORTS. The forms called for in this NVIC are accessible via the CG Portal.



JOHN P. NADEAU
Rear Admiral, U. S. Coast Guard
Assistant Commandant for Prevention Policy

- Enclosure: (1) Testing Facility Guidance
(2) Equipment Manufacturer Guidance
(3) Vessel Certificate Guidance

Testing Facility Guidance

1. U.S. TESTING FACILITY.

- a. Letter of Acceptance. Facilities that are in the business of independently evaluating, inspecting, and testing shipboard sewage systems and the effluent discharged from such systems for compliance with published standards may be eligible to receive a U.S. Coast Guard letter of acceptance as a *qualified facility* to evaluate, inspect, and test *sewage treatment plants* for compliance with MARPOL Annex IV.
- b. Application. A laboratory may, at its discretion, apply to the U.S. Coast Guard to be accepted as a *qualified facility*. Any laboratory previously accepted as a *recognized facility* under 33 CFR Part 159 may also apply to the U.S. Coast Guard for acceptance as a *qualified facility* under MARPOL Annex IV by using these application procedures. The application for acceptance should be made in writing, signed by the chief laboratory official, and include the location of each facility that will evaluate, inspect, and test shipboard sewage systems and the effluent discharged from such systems. Send the application to Commandant (CG-ENG-3) using the address under Contact Information in paragraph 4 below and include the following:
 - (1) A detailed technical report that describes the test rig (see Figure 1), material, and equipment to be used at each facility, including, where applicable, the minimum and maximum operating limits for each piece of equipment to be used;
 - (2) A brief summary of the instrument calibration program at each facility, including, where applicable, the calibration status of each piece of equipment to be used;
 - (3) A brief summary of the relevant training, qualification, and experience for each person who performs, supervises, or witnesses a performance test;
 - (4) A statement affirming that neither the laboratory nor any sub-laboratory, including a subsidiary, is subject to any of the following:
 - (a) Owned or controlled by a supplier, vendor, or manufacturer of equipment or material to be evaluated, inspected, or tested;
 - (b) Dependent on the U.S. Coast Guard for acceptance to remain in business;
 - (c) Advertises or promotes the equipment or material to be evaluated, inspected, or tested;
 - (5) The name, title, address, and principal business activity of each laboratory officer and director as well as each person, company, or corporation that owns at least three percent interest in the laboratory or sub-laboratory, including a subsidiary, or in the company or corporation that controls the laboratory or sub-laboratory; and
 - (6) A statement that an official representative of the U.S. Coast Guard is allowed access to each facility to verify the information submitted in an application or to witness inspections, evaluations, and tests.

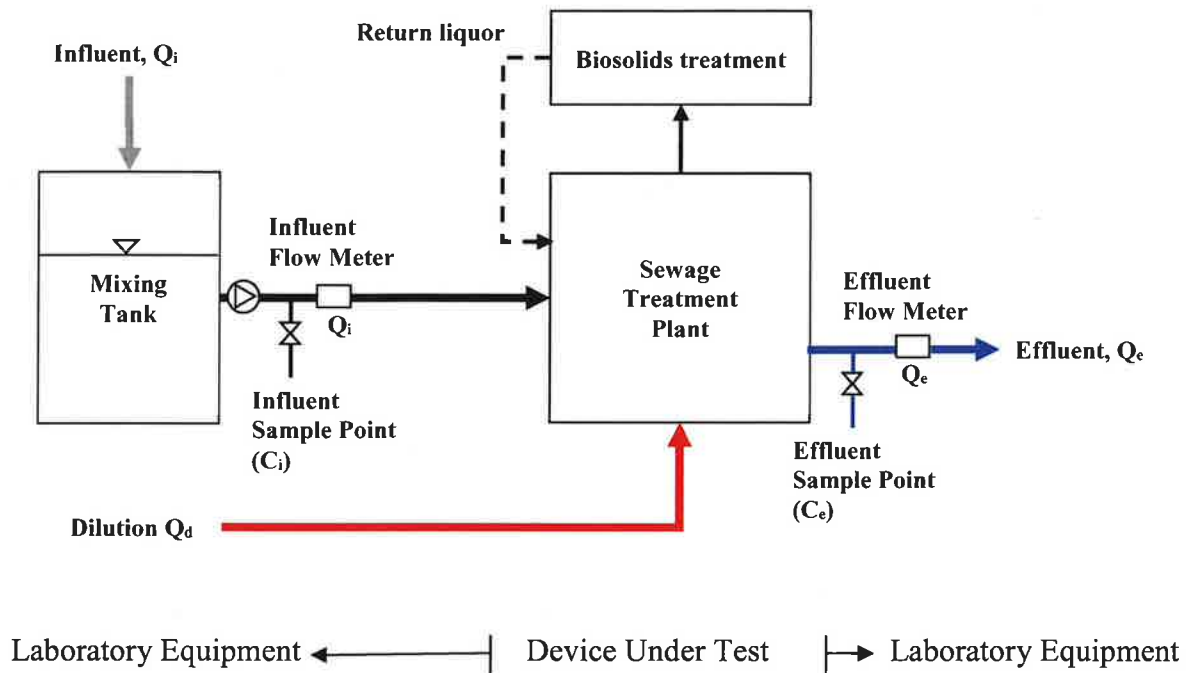

Figure 1: System diagram of a sewage treatment plant

- c. Multiple Laboratories. A letter of acceptance may include one or more sub-laboratories also accepted by the U.S. Coast Guard to perform certain tests on behalf of the *qualified facility*. Under this special arrangement, multiple laboratories having discrete capabilities each perform a defined series of tests on the same device simulating installation onboard ship. The *qualified facility* provides for interfacility coordination and attends each procedure at the sub-laboratory to observe and validate results. Multiple day procedures may be attended selectively during critical periods, e.g., startup, maximum loading, final inspection, etc. For acceptance, the *qualified facility* submits a signed application together with a separate signed application from each sub-laboratory so that when viewed together the consolidated application not only covers all aspects of evaluation, inspection, and testing contained herein but also includes a brief description of how the various facilities will coordinate functions.
- d. Performance Testing Program. The performance testing program composes three discrete protocols, one for each type of sewage system having its own operational requirements and related discharge criteria. In addition, each of these three protocols comprises four phases that start with an evaluation of the manufacturer's documentation and is followed by an inspection of the equipment design and construction, environmental (i.e., mechanical) testing, and finally analytical testing of the effluent.

(1) *Sewage Treatment Plant Protocol*. A qualified facility evaluates, inspects, and tests the manufacturer's *sewage treatment plant* and effluent discharged from that system for compliance with MARPOL Annex IV using the protocol in paragraphs *a* through *d* below.

(a) Documentation evaluation. The laboratory performs an independent evaluation of the manufacturer's documentation as it relates to manufacturing of the *sewage treatment plant* using each of the following standards:

<i>Standard</i>	<i>Title</i>
33 CFR 159.14(b)(1)	Quality control program
33 CFR 159.14(b)(2)	Design drawings
33 CFR 159.14(b)(3)	Instructions

(b) Design & construction inspection. The laboratory performs an independent inspection on the production model for which type approval is requested as well as on the material from which the system is constructed using each of the following standards:

<i>Standard</i>	<i>Title</i>
33 CFR 159.55	Identification label
33 CFR 159.57	Installation, operation, & maintenance instructions
33 CFR 159.59	Placard
33 CFR 159.61	Vents
33 CFR 159.63	Access to parts
33 CFR 159.65	Chemical level indicator
33 CFR 159.67	Electrical component ratings
33 CFR 159.69	Motor ratings
33 CFR 159.71	Electrical controls & conductors
33 CFR 159.73	Conductors
33 CFR 159.75	Overcurrent protection
33 CFR 159.79	Terminals
33 CFR 159.81	Baffles
33 CFR 159.83	Level indicator
33 CFR 159.85	Sewage removal
33 CFR 159.87	Removal fittings
33 CFR 159.89	Power interruption ²
33 CFR 159.93	Independent supporting
33 CFR 159.95	Safety
33 CFR 159.97	Safety; inspected vessels

² NOTE: During the 10 day testing period the device under test shall have the electrical power interrupted for one processing cycle of the device or 30 minutes whichever is greater for each loading volume as specified in the Loading Factor Chart found in MEPC.227(64). For STP that utilizes a Surge Tank, the electrical power shall be interrupted for one processing cycle of the device or 30 minutes whichever is greater. After power is restored, an effluent sample shall be taken and the discharge shall meet the effluent standards. The power interruption sample(s) shall be so noted in the test report. Sewage Treatment Plants intended for use on Inspected Vessels shall also meet the requirements Subchapter F and J of Title 46, Code of Federal Regulations.

- (c) Environmental tests. The laboratory performs independent environmental (i.e., mechanical) testing on the production model for which type approval is requested as well as on the material from which the system is constructed. All testing is performed on the same device installed either onboard ship or ashore, following the manufacturer's instructions. This testing is made using each of the following standards:

<i>Standard</i>	<i>Title</i>
Specification 3.2.2.1, MEPC.107(49) Annex	Vibration. Note: Liquid retention components, if any, filled with water to ½ volume.
33 CFR 159.105	Shock test
33 CFR 159.107	Rolling test
Specification 3.2.2.4, MEPC.107(49) Annex	Inclination ³
Specification 3.2.2.2, MEPC.107(49) Annex	Temperature range
Specification 3.2.2.3, MEPC.107(49) Annex	Humidity
33 CFR 159.117	Chemical resistance test
33 CFR 159.119	Operability test; temp. range
33 CFR 159.129	Ignition prevention test ⁴
33 CFR 159.109	Pressure test
33 CFR 159.111	Pressure & vacuum pulse test

- (d) Analytical tests. The laboratory performs independent analytical testing on effluent discharged from the same device that underwent environmental testing. The laboratory specifies the testing method used along with all variable test conditions, such as quality of influent sewage, loading factors, sampling method, etc., and whether or not the effluent produced visible floating solids or caused discoloration of the surrounding water. This testing is done using the US EPA Test Methods found in the Federal Register <https://federalregister.gov/a/2015-26285> identified in reference (h).

- (2) *Sewage Comminuting and Disinfection System Protocol*. A recognized facility, as defined in reference (e), evaluates, inspects, and tests the manufacturer's *sewage comminuting and disinfection system with holding tank* and the effluent discharged from that system for compliance with MARPOL Annex IV using the procedures for a USCG Type II certified device in 33 CFR Part 159.

³ During the 10 day test period, the device under test shall be inclined at a 22.5° for at least for one processing cycle of the device or 30 minutes whichever is greater for each loading volume as specified in the Loading Factor Chart found in MEPC.227(64). For STP that utilizes a Surge Tank, the STP shall be inclined for one processing cycle of the device or 30 minutes whichever is greater. While inclined, effluent samples shall be taken and the discharge shall meet the effluent standards. The inclined operation samples shall be so noted in the test report.

⁴ Those devices that are not intended to be located in hazardous areas or in an explosive atmosphere are not required to be subjected to the Ignition Prevention Test. In these instances, it shall be documented on manufacturer's instructions and on the Type Approval Certificate that the device is not to be installed in any hazardous areas or in an explosive atmosphere.

- (3) *Sewage Holding Tank Protocol*. A recognized facility, as defined in reference (e), evaluates, inspects, and tests the manufacturer's *sewage holding tank* for compliance with MARPOL Annex IV using the procedures for a USCG Type III certified device in 33 CFR Part 159.

As stated in IMO Resolution MEPC.227(64), an approved MSD should not rely solely on dilution of wastewater in order to meet the effluent limits stipulated in MEPC.227(64). In addition, where amounts of dilution are deemed essential to a treatment process, the effluent standards in Section 4 (of the MEPC.227(674)) should be adjusted proportionally using dilution compensation factor Q_i/Q_e to account for dilution Q_d . In order to demonstrate that an MSD does not solely rely on dilution of waste water to meet the effluent standards, the effluent concentration value, C_e for any particular analyte addressed in resolution MEPC.227(64), Section 4.1 (specifically, TC, TSS, BOD₅, and COD), will need to be less than the effluent standard for that analyte multiplied by the dilution compensation factor Q_i/Q_e . The terms Q_i , Q_e , and Q_d are defined in resolution MEPC.227(64).

For a MSD to be considered by the US Coast Guard, the revised effluent concentration value of any analyte measured at the Effluent Sample Point as shown in Figure 1 of resolution MEPC.227(64), after application of the dilution compensation factor, cannot be below the Test Method Detection Limit for that analyte.

Approved Test Methods are listed in US EPA 40 CFR 136 Guidelines Establishing Test Procedures for the Analysis of Pollutants. The following test methods and detection limits should be used for the following analytes. Alternatively, those ISO standards identified in resolution MEPC.227(64) for COD, BOD, total nitrogen and total phosphorous other internationally accepted equivalent test standard may be used. If an alternative ISO test method or other internationally accepted equivalent test standard is used, the detection limit must still be reported in accordance with the US EPA Minimum Detection Limit.

- Thermotolerant Coliform (TC) Test Method EPA 600/8-78-017 Chapter III⁵ (Detection Limit = 1 colony form unit (CFU)/100 mL),
- Total Suspended Solids (TSS) Test Method 160.2 (Detection Limit = 4.0 mg/L),

⁵ Please refer to Page Number 124 in document USEPA. 1978. Microbiological Methods for Monitoring the Environment, Water, and Wastes. Environmental Monitoring and Support Laboratory, U.S. Environmental Protection Agency, Cincinnati, Ohio. EPA/600/8-78/017; weblink : <http://nepis.epa.gov/Exe/ZyNET.exe/300014TD.txt?ZyActionD=ZyDocument&Client=EPA&Index=1976%20Thru%201980&Docs=&Query=&Time=&EndTime=&SearchMethod=1&TocRestrict=n&Toc=&TocEntry=&QField=&QFieldYear=&QFieldMonth=&QFieldDay=&UseQField=&IntQFieldOp=0&ExtQFieldOp=0&XmlQuery=&File=D%3A%5CZYFILES%5CINDEX%20DATA%5C76THRU80%5CTXT%5C00000000%5C300014TD.txt&User=ANONYMOUS&Password=anonymous&SortMethod=h%7C-&MaximumDocuments=1&FuzzyDegree=0&ImageQuality=r75g8/r75g8/x150y150g16/i425&Display=p%7Cf&DefSeekPage=x&SearchBack=ZyActionL&Back=ZyActionS&BackDesc=Results%20page&MaximumPages=1&ZyEntry=1>

- Biochemical Oxygen Demand (BOD₅) without nitrification⁶ Test Method 5210 B³
(Detection Limit = 2.0 mg/L),
 - Chemical Oxygen Demand (COD) Test Method 410.4 (Detection Limit = 3.0 mg/L),
 - pH Test Method 150.1 (None stated but not normally reported below 0.01. According to the APHA Standard Method accuracy is +/- 0.1 pH under normal conditions.)⁷,
 - Total Nitrogen⁸ Test Method 351.2 (Detection Limit = 0.5 mg/L),
 - Total Phosphorus Test Method 365.2 (Detection Limit = 0.01 mg/L) and Disinfectant residual
 - Chlorine Test Method 330.5 (Detection Limit = 0.2 mg/L)
- e. Certification of Results. The facility that performs the above evaluation, inspection, and testing on a given manufacturer's system and the effluent discharged from that system certifies its test results are accurate and complete in a statement signed by the person in charge of testing. In addition, the laboratory shall report the Detection Limit for the Analytical Test Method used. The Detection Limit may not be below the US EPA established value. These results are part of a detailed technical report that is created by the *qualified facility* and includes a description of each evaluation, inspection, and test performed. The completed report is then forwarded, with all information submitted by the manufacturer, to the Marine Safety Center using the address under Contact Information in paragraph 6 of enclosure (2).
- f. Evaluation of an Existing USCG NVIC 1-09 Approved Device for Change 1. Manufacturers of a USCG Approved NVIC 1-09 device may have their approval reviewed for compliance with NVIC 1-09, Change 1 by an approved laboratory without testing. The manufacturer shall supply the approved laboratory such documentation for evaluation that demonstrates that the approved device does not rely solely on dilution of waste water in order to meet the effluent limits, and that the device is not to be certified for use in Special Areas and that in all respects, the approved device complies with the requirements found in NVIC 1-09, Change 1. The manufacturer shall also supply the approved laboratory such documentation that demonstrates the device has not been changed or modified and remains the same device certified under MEPC.155(59). The

⁶ The equivalent US EPA Test Method for Biochemical Oxygen Demand (BOD₅) without nitrification is done as carbonaceous biochemical oxygen demand (CBOD₅) and should not be confused with the traditional BOD₅ test method which measures "total BOD". The addition of the nitrification inhibitor is not a procedural option, but must be included to report the CBOD₅ parameter.

⁷ There is no US EPA Test Method listed in 40 C.F.R. 136 so the US EPA has adopted American Public Health Association (APHA) Standard Methods for the Examination of Water and Wastewater. The current edition is the 22nd edition.

⁸ Total Nitrogen means the sum of total Kjeldahl nitrogen (organic and ammoniacal nitrogen) nitrate-nitrogen and nitrite-nitrogen.

approved laboratory shall submit a test report that justifies the compliance with Enclosure (1) and why the USCG should extend approval.

2. NON-U.S. TESTING FACILITY. Facilities located outside the United States that are in the business of independently evaluating, inspecting, and testing shipboard sewage systems and the effluent discharged from such systems for compliance with published standards may be eligible to receive a U.S. Coast Guard letter of acceptance as a *qualified facility* by using the same application procedures as described above for U.S. testing facilities.
3. LIST OF LABORATORIES. Any laboratory accepted by the U.S. Coast Guard is issued a letter of acceptance and entered into the Coast Guard Maritime Information Exchange (CGMIX), available on the Web at <http://cgmix.uscg.mil/>. This online searchable database is the official listing of all equipment and laboratories that have been accepted by the U.S. Coast Guard.
4. CONTACT INFORMATION. For more information on this section including acceptance of testing facilities, or to apply for acceptance, please contact:

COMMANDANT (CG-ENG-3)
U.S. COAST GUARD
ATTN: SYSTEMS ENGINEERING DIVISION
2703 MARTIN LUTHER KING JR. AVE. SE STOP 7509
WASHINGTON, D.C. 20593-7509

Equipment Manufacturer Guidance

1. U.S. MANUFACTURER.

- a. Certificate of Approval. Shipboard sewage systems manufactured in the United States in compliance with MARPOL Annex IV may be certified by the U.S. Coast Guard Marine Safety Center (MSC). Type approval is annotated on the U.S. Coast Guard Certificate of Approval issued under MARPOL Annex IV and in compliance with 33 CFR Part 159. A copy of this certificate is provided by the U.S. manufacturer prior to shipboard installation and should be maintained onboard ship for as long as the system is installed.
- b. Application. A U.S. manufacturer may, at its discretion, apply to any facility accepted by the U.S. Coast Guard as a *qualified facility* to perform independent evaluation, inspection, and testing of a *sewage treatment plant* for compliance with MARPOL Annex IV. For *sewage comminuting and disinfection system with holding tank*, the manufacturer may apply to any facility accepted by the U.S. Coast Guard as a *recognized facility*, as defined in reference (e), for compliance with MARPOL Annex IV using the procedures for Application for Certification under 33 CFR 159.14. For *sewage holding tanks*, the manufacturer may apply to any facility accepted by the U.S. Coast Guard as either a *qualified facility* or a *recognized facility*, as defined in reference (e), for compliance with MARPOL Annex IV using the procedures for Application for Certification under 33 CFR 159.14. In all cases, the application for performance testing should be made in writing, signed by a representative of the manufacturer, and include the name and address of the applicant and the manufacturing plant. Send the application and one production model to the *qualified facility* or *recognized facility*, as appropriate, and include the following:
 - (1) The type and size of sewage system to be tested;
 - (2) The specific performance testing standard in enclosure (1) to be used;
 - (3) The sewage system design, including drawings, specifications, and other information that describes the materials, construction, and operation of the plant;
 - (4) The installation, operation, and maintenance instructions for the system;
 - (5) A complete description of the manufacturer's production quality control and inspection methods, record keeping systems that pertain to the manufacturer of the sewage system; and
 - (6) The name and location of the ship to which the sewage system will be installed, and whether testing should be performed either onboard the ship or ashore in the laboratory, or some combination of both.

- c. Certification. The U.S. Coast Guard Marine Safety Center (MSC) may issue a Certificate of Approval to a U.S. manufacturer for any of the following:
- (1) A *sewage treatment plant* may be certified by the MSC to meet the operational requirements in regulation 9.1.1 to MARPOL Annex IV if it is evaluated, inspected, and tested by a *qualified facility* using the *sewage treatment plant* protocol contained in enclosure (1) and produces effluent having no visible floating solids or discoloration on the surrounding water.
 - (2) A *sewage comminuting and disinfecting system with holding tank* may be certified by the MSC to meet the operational requirements in regulation 9.1.2 to MARPOL Annex IV if it is a USCG Type II certified device under 33 CFR Part 159 and is equipped with a holding tank suitable for temporary storage of treated sewage when the ship is less than three nautical miles from the nearest land. Under reference (a), this type of system produces treated sewage that is acceptable for discharge beyond three nautical miles from nearest land, except where otherwise prohibited, and can retain treated sewage in a holding tank when necessary. Stored treated sewage, as well as sewage from spaces containing living animals, may be discharged beyond three nautical miles from nearest land. Although reference (a) prohibits discharge of treated sewage from this type of system while the ship is operating internationally inside three nautical miles from nearest land, a certified USCG Type II device may, under the provisions of reference (e), discharge sewage inside three nautical miles while operating on waters subject to the jurisdiction of the United States, except where otherwise prohibited
 - (3) A *sewage holding tank* contains untreated sewage that is acceptable for discharge beyond 12 nautical miles from land, except where otherwise prohibited. Stored untreated sewage, as well as sewage from spaces containing living animals, may be discharged beyond 12 nautical miles from nearest land at a discharge rate using the calculations in reference (d). Although reference (a) prohibits discharge of sewage from this type of system while the ship is operating internationally inside 12 nautical miles from nearest land, a certified USCG Type III device may, under the provisions of reference (e), discharge sewage beyond three nautical miles while operating on waters subject to the jurisdiction of the United States, except where otherwise prohibited.
- d. Existing Equipment. A U.S. manufacturer may apply to any facility accepted by the U.S. Coast Guard as a *qualified facility* or as a *recognized facility*, as appropriate, to perform independent evaluation, inspection, and testing of any existing sewage system for compliance with MARPOL Annex IV by using the same application procedures as described above for U.S. manufacturers. The *qualified facility* or *recognized facility* follows the testing and reporting procedures applicable to that device. Installed systems may only be removed from a U.S. flagged vessel for purposes of certification by following the manufacturer's removal instructions. For inspected vessels, prior written approval is needed from the local Officer in Charge, Marine Inspection (OCMI) before any installed systems may be removed. For vessels enrolled in the Alternate Compliance Program (ACP) prior written approval is obtained instead from the ship's Authorized Classification Society (ACS). In any case, all vessels remain subject to the requirements of treating or retaining sewage as provided for in reference (e) while operating in waters subject to the jurisdiction of the United States.

Manufacturers of a USCG Approved NVIC 1-09 device may have their approval reviewed for compliance with NVIC 1-09, Change 1 by an approved laboratory without testing. The manufacturer shall supply the approved laboratory such documentation for evaluation that demonstrates that the approved device does not use additional process water (Qd), that the device is not to be certified for use in Special Areas and that in all respects, the approved device complies with the requirements found in NVIC 1-09, Change 1. The manufacturer shall also supply the approved laboratory such documentation that demonstrates the device remains in all material respect the same device certified under MEPC.159(55). The approved laboratory shall provide the Marine Safety Center with a report stating that they have reviewed the manufacturers documentation and find the device meets the requirements of MEPC.227(64) without additional testing.

2. NON-U.S. MANUFACTURER.

Shipboard sewage systems manufactured outside the United States in compliance with MARPOL Annex IV may be eligible for type approval by the MSC. A non-U.S. manufacturer may, at its discretion, apply to any facility accepted by the U.S. Coast Guard as a *qualified facility* or a *recognized facility*, as appropriate, to perform independent evaluation, inspection, and testing of a sewage system for compliance with Annex IV by using the same application procedures as described above for U.S. manufacturers. The *qualified facility* or *recognized facility* follows the testing and reporting procedures that are applicable for the given type of system. Type approval is annotated on the U.S. Coast Guard Certificate of Approval. A copy of the certificate is provided by the manufacturer prior to installation and should be maintained onboard the ship for as long as the system is installed.

Manufacturers of a USCG Approved NVIC 1-09 device may have their approval reviewed for compliance with NVIC 1-09, Change 1 by an approved laboratory without testing. The manufacturer shall supply the approved laboratory such documentation for evaluation that demonstrates that the approved device does not use additional process water (Qd), that the device is not to be certified for use in Special Areas and that in all respects, the approved device complies with the requirements found in NVIC 1-09, Change 1. The manufacturer shall also supply the approved laboratory such documentation that demonstrates the device remains in all material respect the same device certified under MEPC.159(55). The approved laboratory shall provide the Marine Safety Center with a report stating that they have reviewed the manufacturers documentation and find the device meets the requirements of MEPC.227(64) without additional testing.

3. RECIPROCITY.

A shipboard sewage system having non-U.S. Coast Guard type approval may be eligible for type approval by the MSC. A manufacturer may apply to any facility accepted by the U.S. Coast Guard as a *qualified facility* or a *recognized facility*, as appropriate, to perform independent evaluation, inspection, and testing of sewage systems for compliance with MARPOL Annex IV by using the same application procedures as described above for U.S. manufacturers, being certain to include a copy of all prior test reports. The *qualified facility* or *recognized facility* follows the same testing and reporting procedures that are applicable for the given type of system and may, where appropriate, accept prior results having testing protocols that are substantially

equivalent to those listed in the applicable protocol in enclosure (1). Type approval is annotated on the U.S. Coast Guard Certificate of Approval. A copy of the certificate is provided by the manufacturer prior to installation and should be maintained onboard the ship for as long as the system is installed.

4. SCALING. Only full-scale production quality *sewage treatment plants* may be accepted for evaluation, inspection, and testing under MARPOL Annex IV. Such plants are of the actual size and capacity to be installed onboard ships. However, a manufacturer may apply in writing to the Marine Safety Center using the address under Contact Information in paragraph 6 below for a defined range of equipment sizes that employ the same design principles and technology using prior test results from a U.S. Coast Guard certified system.

5. LIST OF EQUIPMENT. Equipment certified by the MSC under MARPOL Annex IV are issued a Certificate of Approval and entered into the Coast Guard Maritime Information Exchange (CGMIX), available on the Web at <http://cgmix.uscg.mil/>. This online searchable database is the official listing of all equipment and laboratories that have been accepted by the U.S. Coast Guard.

6. CONTACT INFORMATION. For more information on this section including equipment certification or design review, please contact:

COMMANDING OFFICER (MSC)
ATTN MARINE SAFETY CENTER
US COAST GUARD STOP 7430
2703 MARTIN LUTHER KING JR. AVE. S.E.
WASHINGTON, D.C. 20593-7430

E-mail Submissions: E-mail submissions are welcome and must be sent to msc@uscg.mil. The aggregate size of all attachments to an e-mail cannot exceed 10 MBs. The subject line of the e-mail cannot exceed 250 characters and must contain the applicable MSC Project Number (P0#####) or include the text "New Project." Each e-mail submission will receive an automated e-mail response to confirm receipt. If your plan review submission is rejected by MSC's e-mail multiple times or you do not receive a confirmation e-mail indicating that your submission has been processed, please contact the Electronic Commerce Officer at (202) 795-6729 for assistance.

Vessel Certificate Guidance

1. U.S. REGISTRY.

- a. Statement of Voluntary Compliance. Vessels registered in the United States that engage in international voyages with sewage systems in compliance with MARPOL Annex IV may be eligible to receive a Statement of Voluntary Compliance (SOVC). This certificate takes the place of the International Sewage Pollution Prevention Certificate (ISPPC) and is only issued to U.S. vessels to demonstrate compliance with MARPOL Annex IV.
- b. Application. The owner or operator of a vessel registered in the United States with an installed and operational sewage system type approved by the U.S. Coast Guard may, at their discretion, apply for a SOVC for MARPOL Annex IV. The application for SOVC should be in writing, signed by the vessel owner or operator, and contain the name and address of the applicant. Send the application to the local Officer in Charge, Marine Inspection (OCMI), or to the Authorized Classification Society (ACS), as appropriate, and include the following:
 - (1) Vessel name and official number;
 - (2) Port of registry;
 - (3) Gross tonnage;
 - (4) Number of persons, including both passengers and crew, that the vessel is certified to carry;
 - (5) IMO Number, if any; and
 - (6) Copy of the U.S. Coast Guard Certificate of Approval indicating that the installed sewage system is one of the following approved types:
 - (a) *A sewage treatment plant* certified by the U.S. Coast Guard under the provisions of MEPC.227(64) or MEPC.159(55) to meet the operational requirements in regulation 9.1.1 to MARPOL Annex IV. Include a copy of the laboratory test results, which are attached to the U.S. Coast Guard Certificate of Approval.
 - (b) *A sewage comminuting and disinfecting system with holding tank* approved by the U.S. Coast Guard as a Type II MSD under the provisions of 33 CFR Part 159 to meet the operational requirements in regulation 9.1.2 to MARPOL Annex IV.

Sewage holding tanks may be certified by the OCMI or ACS as meeting the requirements of 9.1.3 of MARPOL Annex IV. This can be accomplished during the survey required by paragraph c. Owners or operators requesting an SOVC for a sewage holding tank should follow the above application procedures and should provide the following additional information:

- (1) Tank capacity;
- (2) Tank location;
- (3) Maximum Service Speed

(4) Maximum Summer Draft; and

(5) Vessel Breadth

During the survey, the OCMI or ACS should validate the above information and determine if the capacity is sufficient for the retention of all sewage, (taking in account the operation of ship and the number of persons on board), the construction is satisfactory, and a means to indicated visually the amount of contents is provided.

- c. Survey. The cognizant OCMI or ACS, as appropriate, performs an examination of the vessel at any of the following:
- (1) Initial Survey. The vessel is subject to an initial examination before the ship is put into service or before the SOVC is issued for this first time. The purpose of this examination is to verify that the vessel's structure, equipment, systems, fittings, arrangement, and material of the installed sewage system are fully compliant with MARPOL Annex IV.
 - (2) Renewal Survey. The vessel is subject to a renewal examination before five years after the initial or last renewal survey. The purpose of this examination is to verify that the vessel's structure, equipment, systems, fittings, arrangement, and material of the installed sewage system are compliant with MARPOL Annex IV. If the renewal survey is completed within three months either before or after expiration of the certificate then the new expiration will be set ahead five years from the old expiration date, otherwise the new expiration will be reset to five years after the examination date.
 - (3) Additional Survey. The vessel is subject to additional examinations, either general or partial, according to the circumstances, whenever any important repairs or renewals have been made to the installed sewage system. The purpose of this examination is to verify that the necessary repairs or renewals have been effectively made, that the materials and workmanship of such repairs or renewals are satisfactory, and that the ship is compliant with MARPOL Annex IV.
- d. Issuance of Statement of Voluntary Compliance. The cognizant OCMI or ACS may issue or renew, as appropriate, a SOVC for MARPOL Annex IV to a U.S. vessel that is equipped with an installed and operational sewage system or sewage holding tank certified by the U.S. Coast Guard after successful onboard survey. Coast Guard Marine Inspectors may download an electronic version of the SOVC certificate, form CG-6047A, from the Coast Guard's electronic forms page. To complete the SOVC and perform the following steps to the electronic document:
- (1) Fill in the vessel's particulars e.g., name, official number, etc., including the number of persons (i.e., passengers and crew) that the vessel is certified to carry. It is not necessary to include M/V before the name or D before the official number.
 - (2) Place an X in the appropriate box corresponding to either *new* or *existing* ship.

- (a) *New* is a ship having a keel laid date on or after September 27, 2003, or a delivery date on or after September 27, 2006.
- (b) *Existing* is a ship having a keel laid date before September 27, 2003, or a delivery date before September 27, 2006.
- (3) Insert the vessel's keel laid date or delivery date, as appropriate.
- (4) Select the type of sewage system installed onboard the vessel by placing an X in the appropriate box for .1 Sewage Treatment Plant, .2 Comminuter, and/or .3 Holding Tank. For each type of installed system, enter the equipment particulars in the area below the checked box. Vessels equipped with more than one type of system may have an X placed in all that apply.
- (a) For *sewage treatment plant*, enter the equipment model number in type of sewage treatment plant, the name of the manufacturer, and indicate the applicable effluent standard under MARPOL Annex IV by placing an X in either MEPC.2(VI), MEPC.159(55), MEPC.227(64) or National Specification (33 CFR 159) depending on applicability. For MEPC.227(64), indicate in the drop-down menu whether the sewage treatment plant includes or does not include compliance with Section 4.2 (Nitrogen/Phosphorus). See the U.S. Coast Guard Certificate of Approval for equipment particulars.
- (b) For *comminuter*, enter the equipment model number in type, the name of the manufacturer, and enter 33 CFR Part 159 – Type II in standard of sewage after disinfection. Do not enter any particulars of a holding tank that is part of a comminuter system. See the U.S. Coast Guard Certificate of Approval for equipment particulars.
- (c) For *holding tank*, enter the tank capacity, location of the tank, and other equipment particulars being careful to enter all values in SI units as indicated on the form. Do not enter any particulars of a holding tank that is part of a comminuter system. The values entered for maximum service speed, maximum summer draft, and breadth on page 1 of the form will automatically generate a table on page 2 indicating the maximum permissible discharge rates for untreated sewage. See the U.S. Coast Guard Certificate of Approval for equipment particulars.
1. Tank capacity. Enter the total capacity (i.e., volume) of the holding tank in cubic meters. To convert from English to SI units, multiply cubic feet by 0.02832 to obtain cubic meters or multiply gallons by 0.003785 to obtain cubic meters.
 2. Location. Enter the physical location of the holding tank using space, frame, side, etc.
 3. Maximum service speed. Enter the maximum service speed in knots from data on the vessel's speed curve.

4. Maximum summer draft. Enter the maximum summer draft (i.e., deepest draft) in meters by subtracting the summer freeboard listed on load line certificate from the total molded depth. Multiply feet by 0.3048 to obtain meters.
 5. Breadth. Enter the breadth of the vessel in meters directly from the tonnage certificate. Multiply feet by 0.3048 to obtain meters.
- (5) In the blank after *This Certificate is valid until*, insert the SOVC validity (i.e., expiration) date by selecting a date that is not more than five years from the date of issue. See also paragraph 1.c.(2) above for setting an expiration date following a renewal survey.
 - (6) In the blank after *Completion date of survey*, insert the date that the installed sewage system was recently examined or surveyed by OCMI or ACS.
 - (7) In the two blank spaces after *Issued at*, insert the city and state where the SOVC is being issued.
 - (8) Attach the following documents to the SOVC:
 - (a) For *sewage treatment plants*, attach a copy of the U.S. Coast Guard Certificate of Approval and a copy of the laboratory test results.
 - (b) For *sewage comminuting and disinfecting system with holding tank*, attach a copy of the U.S. Coast Guard Certificate of Approval. Laboratory test results are not required.
 - (9) Insert the date of issue and the name and title of the person signing on behalf of the OCMI or ACS. Sign the document in blue ink and affix a crimped seal.
 - (10) Scan the signed original SOVC including appropriate attachments into MISLE. See paragraph 3 below for MISLE entry requirements.
 - (11) Send the signed original SOVC including appropriate attachments to the vessel.
- e. Endorsements to Extend Certificate. The reverse side of the SOVC contains three endorsements to extend the validity period of an existing certificate. When the SOVC is first issued, these endorsements are usually blank. The cognizant OCMI or ACS, as appropriate, may later endorse an original SOVC using the guidance contained in the relevant MARPOL Annex IV regulations that are cited after each endorsement (e.g., regulation 8.3) on the form. After endorsing an SOVC, scan a copy into documents in MISLE and provide the signed original endorsed SOVC to the vessel. See paragraph 3 below for MISLE entry instructions.
 - f. Safety Management. Ship staff training should also include familiarization in the operation and maintenance of the sewage system as required by the Ship's Safety Management System under the ISM Code.
 - g. Casualty and Repair. The owner or operator of a U.S. registered vessel that holds a SOVC for MARPOL Annex IV should notify, as soon as practicable, the nearest OCMI or ACS, as appropriate, of any system degradation (e.g., defect, accident, malfunction, etc.) that affects the

performance of the installed sewage system. The cognizant OCMI or ACS may, at its discretion, allow a reasonable period of time for repairs to be made or allow the vessel to proceed to an alternate port or repair yard, as appropriate, for repairs especially when the vessel does not present an unreasonable threat of harm to the marine environment. In this case, form CG-835 may be used.

- h. Non-Compliance. The cognizant OCMI or ACS may, at its discretion, withdraw a SOVC held by a U.S. vessel found not substantially compliant with the provisions of MARPOL Annex IV especially when that vessel presents an unreasonable threat of harm to the marine environment. Any non-compliance will be documented in MISLE.
- i. Expiration. The SOVC for MARPOL Annex IV becomes invalid at expiration unless endorsed with an extension and immediately after a change in the vessel's flag.
- j. U.S. Regulations. Any U.S. registered vessel that holds a valid SOVC for MARPOL Annex IV will be accepted by the U.S. Coast Guard as being in compliance with U.S. regulations contained in reference (e) as it relates to the design, construction, testing, and certification of sewage systems, while operating in waters subject to the jurisdiction of the United States.
- k. Existing Certificates of Equivalency. The cognizant OCMI or ACS, as appropriate, may continue to issue and renew existing Certificates of Equivalency to U.S. vessels under the provisions of MOC Policy Letter No. 03-03 until January 1, 2010, at which time all such certificates will expire. SOVC certificates are required on or after January 1, 2010.

2. NON-U.S. REGISTRY.

- a. Reciprocity. Any vessel flagged or registered outside the United States that holds a valid ISPPC issued by its flag Administration indicating the installed sewage system complies with MARPOL Annex IV as amended by resolutions MEPC.227(64), MEPC.159(55) or MEPC.2(VI) will be accepted by the U.S. Coast Guard as being in compliance with U.S. regulations contained in reference (e) as it relates to the design, construction, testing, and certification, while operating in waters subject to the jurisdiction of the United States.
- b. Compliance. Acceptance of a valid ISPPC is conditional on the installed sewage system being substantially in an operable condition as required by MARPOL Annex IV and may be subject to verification by the U.S. Coast Guard under port State control.
- c. Non-compliance. Any vessel flagged or registered outside the United States that is not in compliance with MARPOL Annex IV is required instead to comply with 33 CFR Part 159 while operating in waters subject to the jurisdiction of the United States. Other applicable U.S. laws or regulations may provide for enforcement actions in the case of non-compliance e.g., discharge of sewage, negligence, etc. Additionally, any vessel operating on waters subject to the jurisdiction of the United States that is non-compliant with MARPOL Annex IV and non-compliant with 33 CFR Part 159 may be subject to control actions restricting the movement of the vessel as deemed appropriate by the Captain of the Port (COTP).
- d. Statement of Voluntary Compliance. SOVC certificates issued by the U.S. Coast Guard are not available to vessels flagged outside the United States.

3. MISLE Entries. The inspector that performs a MARPOL Annex IV examination (e.g., initial survey, renewal survey, etc.) shall enter the results in MISLE. First create a new vessel activity and then select activity type *Vessel Inspection/PSC*. For activity title/description, enter *MARPOL Annex IV Examination*. Under the inspections tab add a new inspection and select inspection type of *MARPOL Annex IV Examination* from the drop down list, being certain to select the correct entry having Roman numeral four (IV). Provide a brief narrative summary that includes the type of survey performed (e.g., initial survey, renewal survey, etc.) and results of the examination. See survey paragraph 1.c above for sample language. Once signed, scan the original SOVC, front and back, and all related attachments from paragraph 1.d. (8) above as one document into MISLE. If the examination activity is still open, then simply add the scanned documents to Documents/Certificates and select document type *MARPOL Annex IV SOVC* from the drop down list, being certain to select the correct entry having Roman numeral four (IV). Otherwise add the scanned documents to the vessel's *Documents* file in MISLE. For certificate entry in MISLE, enter the certificate issue date and expire date, leaving blank the certificate number and audit survey date. Once the activity is complete, it may be reviewed and closed at the field unit level or as otherwise required by local instruction. When the SOVC is issued by an ACS, the OCMI shall ensure a copy is obtained and entered in to MISLE as above.
4. CONTACT INFORMATION. For more information on this section including vessel certificates and reciprocity, please contact:

COMMANDANT (CG-CVC)
U.S. COAST GUARD
ATTN: OFFICE OF VESSEL ACTIVITIES
2703 MARTIN LUTHER KING JR AVE. SE STOP 7509
WASHINGTON, DC 20593-7509